



WOJNAROWSKI

PREZENTUJE

LIGHTING

COLLECTION



U.M.A.G.E.



“How are you intrigued when you look at something for the first time? We want people to connect with our designs on an emotional level. Ultimately, the first thing you can do is to have a deep connection or appreciation of the object”

Soren Ravn Christensen, Chief Creative Developer



We take the story of Scandinavian design further than ever before by combining aesthetics, simplicity and functionality and infusing it with thoughtful craftsmanship and environmental care. Our designs are deeply rooted in the diverse urban landscape and raw nature surrounding our home in the heart of Copenhagen, Denmark.

We develop innovative packaging solutions to optimise global logistics, reduce storage and transportation costs and to make our designs more accessible and affordable. In the process, we minimise the carbon footprint on our planet and maximise our ethical commitment to environmental responsibility

Having begun our journey in 2008, we have been constantly growing and expanding. Today, UIMAGE is present in over 2000 stores in 40 countries around the world.

**"My experience is that the simplest shapes
frame the beauty of wood the best"**

Asger Risborg Jakobsen, Designer





Put nature in the spotlight with the Chimes lamp

A wooden pendant lamp in its simplest and cleanest form, Chimes brings the Nordic tones of nature into the interior.

A piece of solid oak, combined with a warm LED light source, Chimes is based on the graceful lines that occur from rows of trees in the woods.

The lamp's focused spot makes a good reading light beside a chair or over a dining or coffee table and has a cosy candlelight quality for relaxed evenings in the company of friends.





wood



Wood



Oak 2165



Dark Oak 2167

Chimes | pendant

Item no. ● Oak 2165
● Dark Oak 2167

Ⓜ Materials Oak. Includes 2m black cord & black metal canopy driver

⊕ Dimensions Ø: 3 x H: 22 cm

⚙ Use Pendant

💡 Light LED panel built-in. 3000 k, 220 lm, 80 ra.

Designer Asger Risborg Jakobsen

**“Some lampshades are just so beautiful
that you feel compelled to make them”**

Lorenzo Radaelli, Designer





Dynamic light and shadow with the Ribbon lampshade

With its soft translucent strips interwoven into a delicate organic shape, the Ribbon lampshade is a sculptural object that sends a warm glow of light into the space.

Ribbon's careful construction of curves and folds gives the lampshade a dynamic mix of light and shadow on its surface.

Use Ribbon as a centerpiece in the living room or hang one or two lampshades over the dining table or kitchen island.



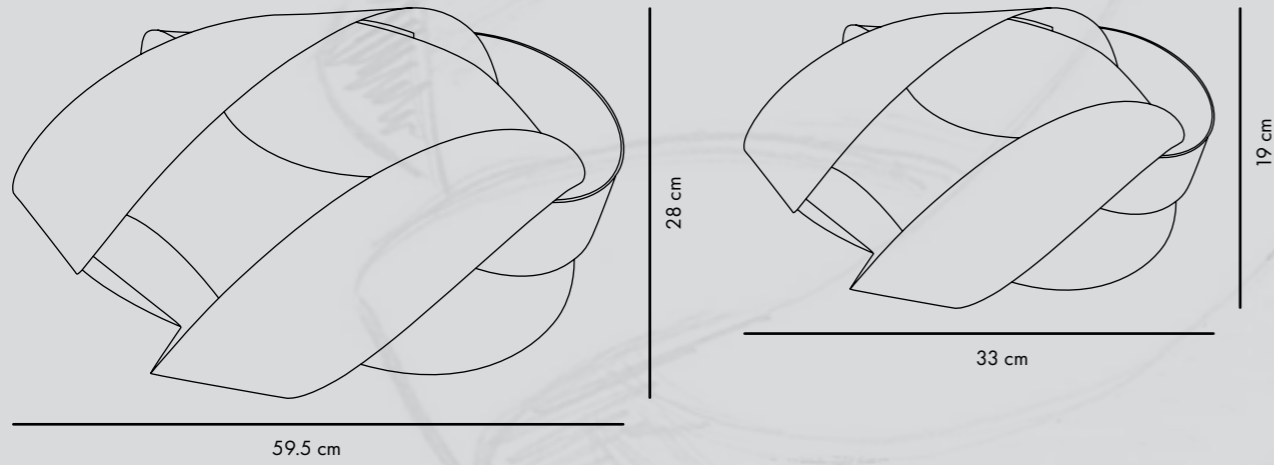

Ribbon medium | lampshade

Item no. White 2163

 Materials Polypropylene

 Dimensions Ø: 49.5 x H: 28 cm

 Use Pendant, wall, & floor lamp

 Light E27 / E26 - max 15 W LED

Designer Lorenzo Radaelli

Ribbon mini | lampshade

Item no. White 2164

 Materials Polypropylene

 Dimensions Ø: 33 x H: 19 cm

 Use Pendant, wall, floor & table lamp

 Light E27 / E26 - max 15 W LED

Designer Lorenzo Radaelli

Polypropylene

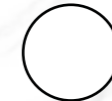

White
2163/2164

“Imagine if flowers could light up”

Soren Ravn Christensen, Chief Creative Developer





Explore life and nature with Aluvia

With characteristic geometrical blades made from aluminium, the Aluvia lampshade has a distinctive edge, while being lightweight and durable at the same time.

Aluvia amplifies the beauty of your interior design, making your home cosy, classic and refined, while also bringing a touch of nature inside through its organic shape.

Start your journey from the depths of the oceans, to the bustling city, passing through the enchanting forests, all in one eclectic product.

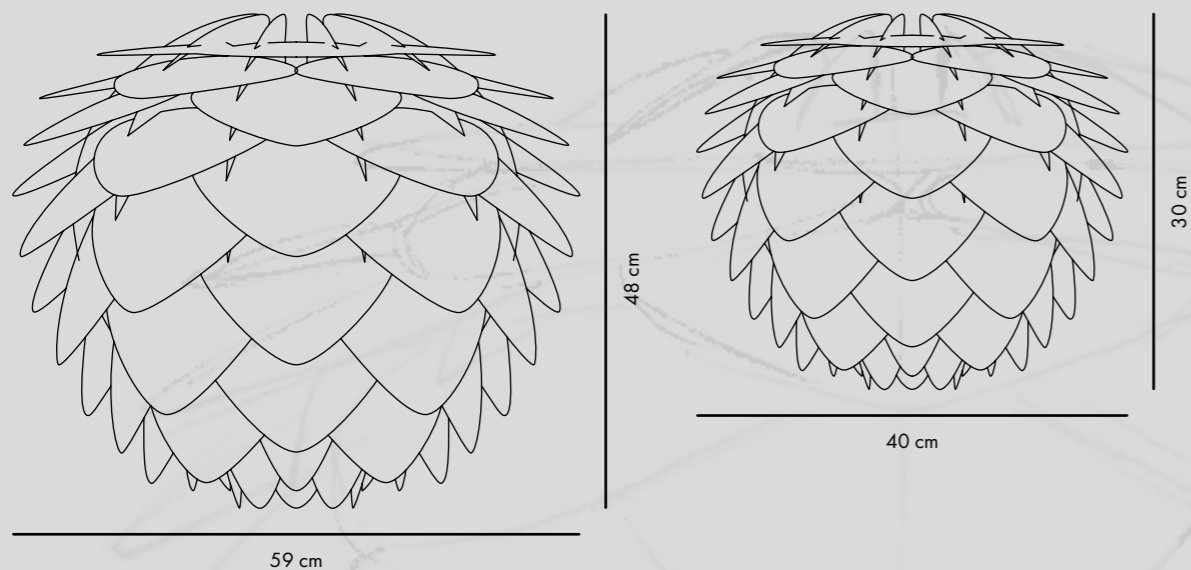

Aluvia medium | lampshade

- # Item no.
- Pearl White 2127
 - Anthracite Grey 2129
 - Forest Green 2131
 - Petrol Blue 2133
 - Ruby Red 2135
 - Saffron Yellow 2137

Materials Aluminium, PP & PC

Dimensions Ø: 59 x H: 48 cm

Use Pendant, floor & table lamp
Flip 180°

Light E27 / E26 - max 15 W LED

Designer Soren Ravn Christensen

Aluvia mini | lampshade

- # Item no.
- Pearl White 2128
 - Anthracite Grey 2130
 - Forest Green 2132
 - Petrol Blue 2134
 - Ruby Red 2136
 - Saffron Yellow 2138

Materials Aluminium, PP & PC

Dimensions Ø: 40 x H: 30 cm

Use Pendant, wall, floor & table lamp
Flip 180°

Light E27 / E26 - max 15 W LED

Designer Soren Ravn Christensen

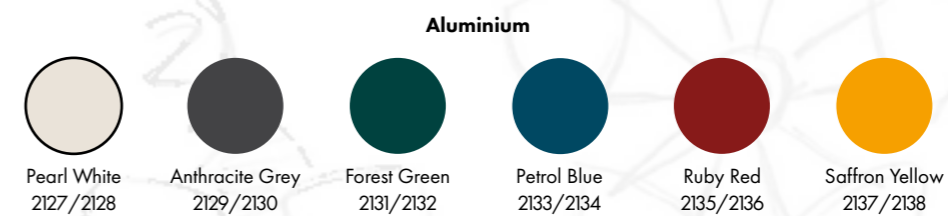



“The illusion of earthly weightlessness had to be challenged by a light design that defies gravity”

Soren Ravn Christensen, Chief Creative Developer





Experience the colours of nature and light with Asteria

Born at the crossroads of design, technology and craftsmanship, the Asteria series of lamps incorporate built-in LED lights into a sleek, minimalist shape.

Casting a bright, lively light, Asteria comes in a seductive and modern six-colour palette to match and complement any interior design, from a contemporary or high design decor to a futuristic or even retro one.

Place it above the coffee table or dinner table; its slim shape will ensure that nothing obscures the view of guests sitting opposite you and its diffused light will ensure a blind-free glow.

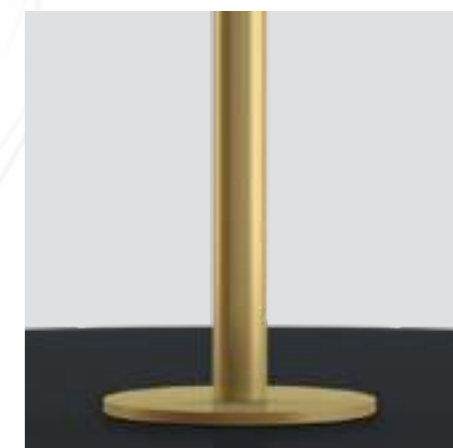

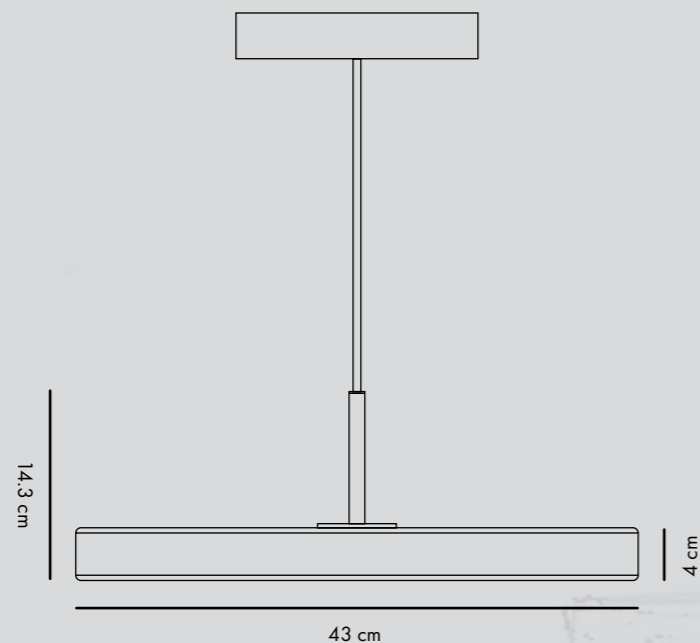

Asteria | lamp

# Item no.	<ul style="list-style-type: none"> ○ Pearl White 2151 ● Anthracite Grey 2152 ● Forest Green 2153 ● Petrol Blue 2154 ● Ruby Red 2155 ● Saffron Yellow 2156
M Materials	Steel, Aluminium, PMMA. Incl. 2m textile cord.
D Dimensions	Ø: 43 x H: 4 cm (H: 14.3 cm incl. brass bracket)
U Use	Pendant
L Light	LED panel built-in. Dimmable. 3000 k, 1500 lm, 80 ra, 17kWh/1000h
Designer	Soren Ravn Christensen

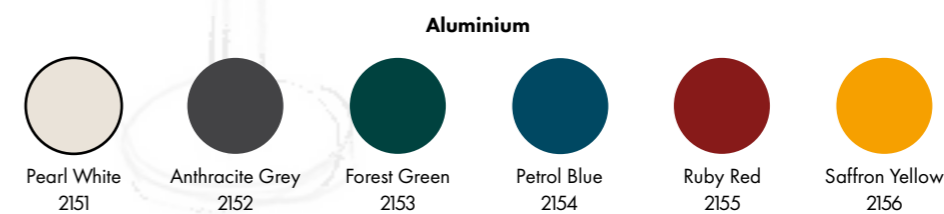

“Light as a feather”

Soren Ravn Christensen, Chief Creative Developer



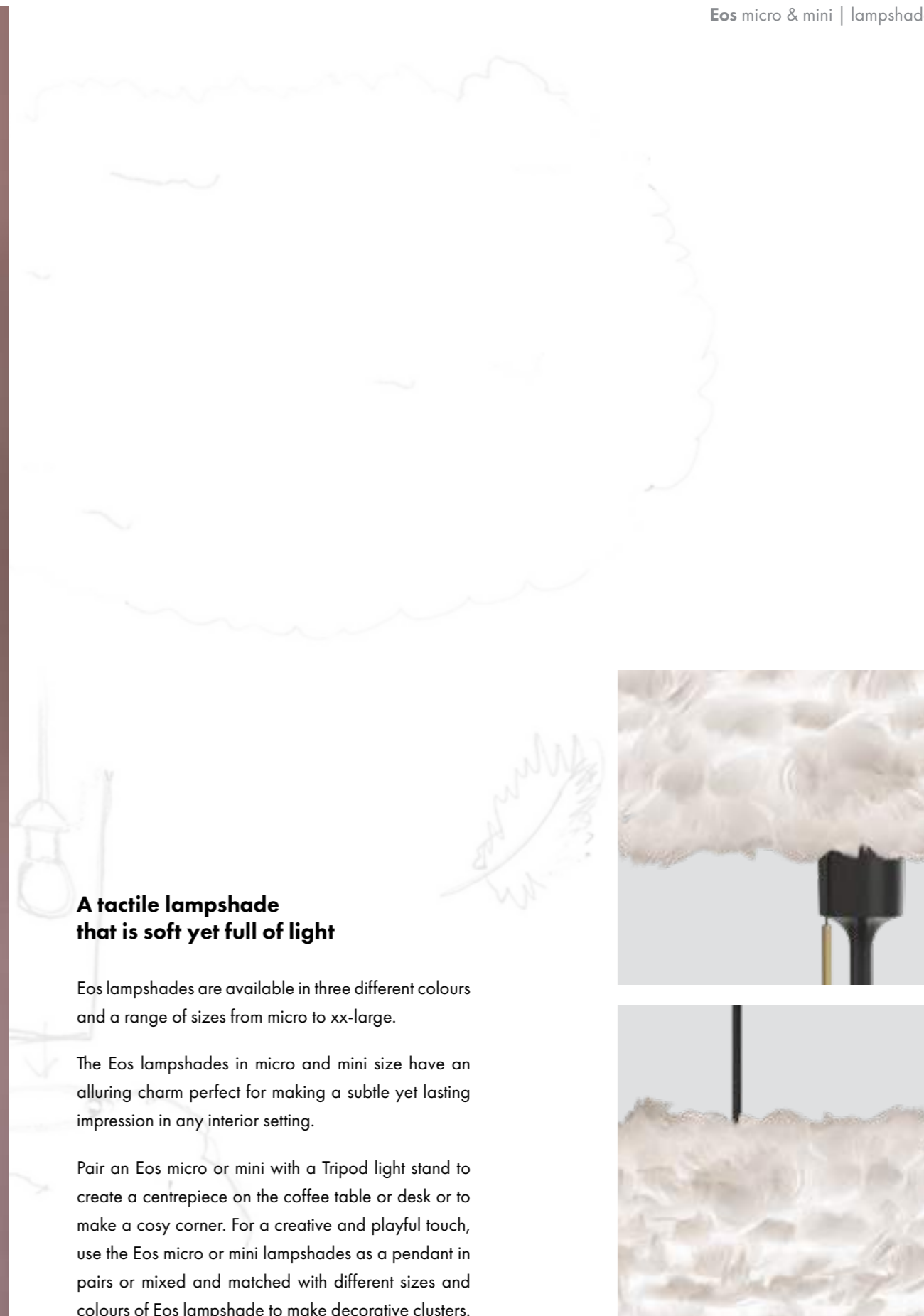

A tactile lampshade that is soft yet full of light

Eos lampshades are available in three different colours and a range of sizes from micro to xx-large.

The Eos lampshades in micro and mini size have an alluring charm perfect for making a subtle yet lasting impression in any interior setting.

Pair an Eos micro or mini with a Tripod light stand to create a centrepiece on the coffee table or desk or to make a cosy corner. For a creative and playful touch, use the Eos micro or mini lampshades as a pendant in pairs or mixed and matched with different sizes and colours of Eos lampshade to make decorative clusters.

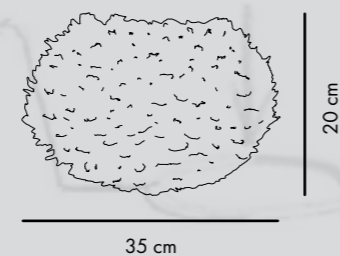
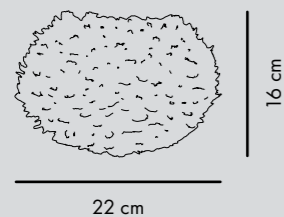

Eos micro | lampshade

- # Item no. White 2091
 Light Grey 2123
 Light Brown 2125

Materials Goose feathers

Dimensions Ø: 22 x H: 16 cm

Use Pendant, wall, floor & table lamp

Light E27 / E26 - max 15 W LED

Designer Soren Ravn Christensen

Eos mini | lampshade

- # Item no. White 2011
 Light Grey 2124
 Light Brown 2126

Materials Goose feathers

Dimensions Ø: 35 x H: 20 cm

Use Pendant, wall, floor & table lamp

Light E27 / E26 - max 15 W LED

Designer Soren Ravn Christensen

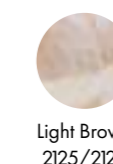
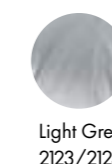
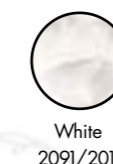

White
2091/2011

Light Grey
2123/2124

Light Brown
2125/2126

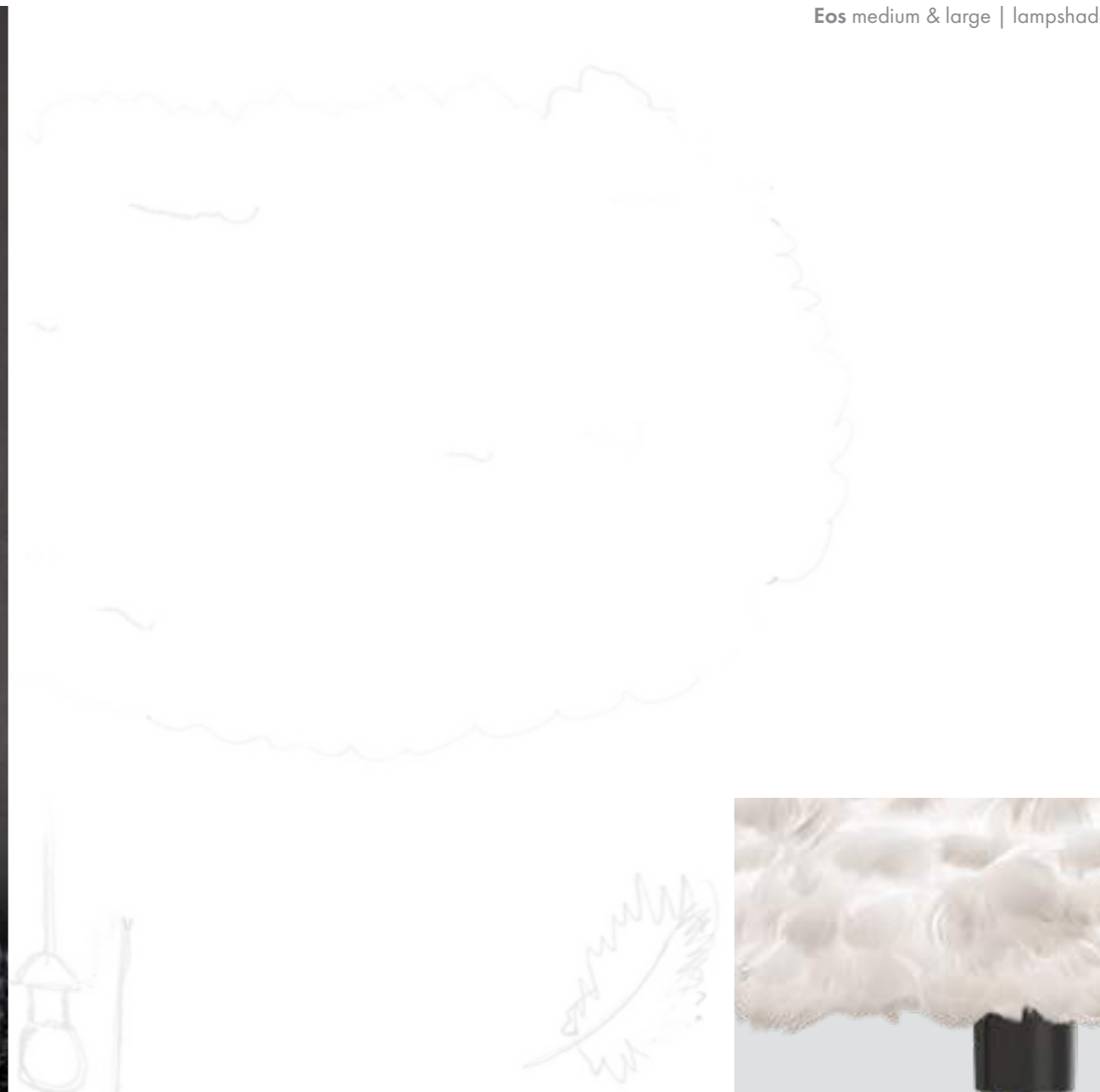

Inspired by the earth tones of the Nordic landscape

Eos lampshades in medium & large size give a soft, warm light that adds a cosy yet elegant touch to any interior setting.

All Eos lampshades are available in a neutral and harmonious colour palette just right for creating a warm and welcoming atmosphere at home.

Eos lampshades in medium & large bring a distinctive sense of comfort and elegance to the space, whether in a contemporary living room or in a classic bedroom.

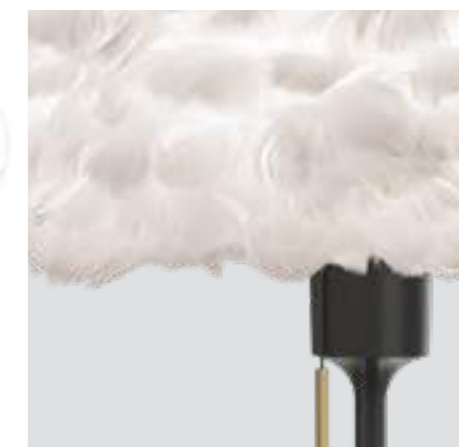

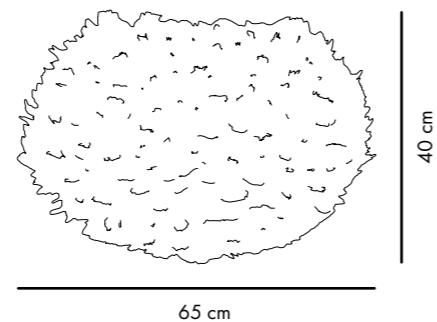
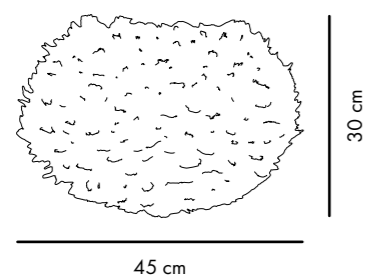

Eos medium | lampshade

- # Item no. White 2010
 Light Grey 2085
 Light Brown 2066

Materials Goose feathers

Dimensions Ø: 45 x H: 30 cm

Use Pendant, wall, floor & table lamp

Light E27 / E26 - max 15 W LED

Designer Soren Ravn Christensen

Eos large | lampshade

- # Item no. White 2042
 Light Grey 2090
 Light Brown 2089

Materials Goose feathers

Dimensions Ø: 65 x H: 40 cm

Use Pendant & floor lamp

Light E27 / E26 - max 15 W LED

Designer Soren Ravn Christensen





Add a sophisticated and elegant touch with a soft edge

Eos lampshades in x-large & xx-large sizes give you the possibility of adding the soft, cosy light to larger interior settings.

Use the x-large & xx-large sizes of Eos lampshades to create an eye-catching design statement in the bedroom, dining room or living room, adding a sensual and warm touch to interiors on a grander scale.

With a range of unique and distinctive Eos lampshades in multiple sizes, you have every chance of finding the perfect size of lampshade to fit your home and office.



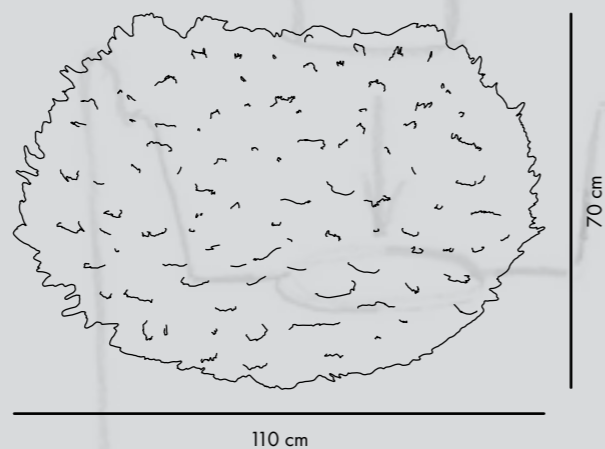
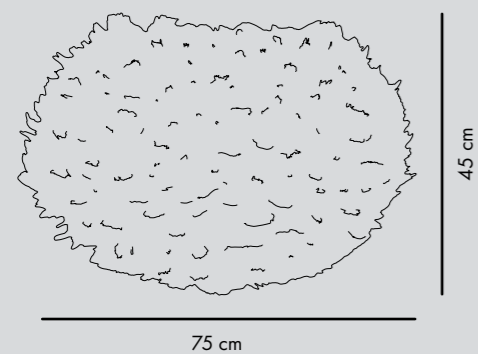

Eos x-large | lampshade

Item no. White 2012
 Light Grey 2086
 Light Brown 2067

Materials Goose feathers

Dimensions Ø: 75 x H: 45 cm

Use Pendant

Light E27 / E26 - max 15 W LED

Designer Soren Ravn Christensen

Eos xx-large | lampshade

Item no. White 2041

Materials Goose feathers

Dimensions Ø: 110 x H: 70 cm

Use Pendant

Light E27 / E26 - max 15 W LED

Designer Soren Ravn Christensen

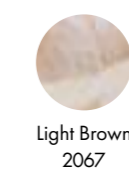
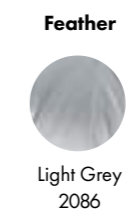
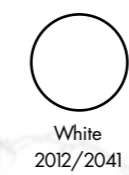

**“Whether it’s in width or height,
you need light to make your small areas
come to life”**

Soren Ravn Christensen, Chief Creative Director





Find the better half with the Eos Up lampshade

The Eos Up is the perfect companion for small spaces in need of big designs.

Eos Up gives a soft, warm light that adds a sophisticated and elegant touch to any interior decor.

Its clever construction makes it easy to mount directly onto the ceiling or wall.



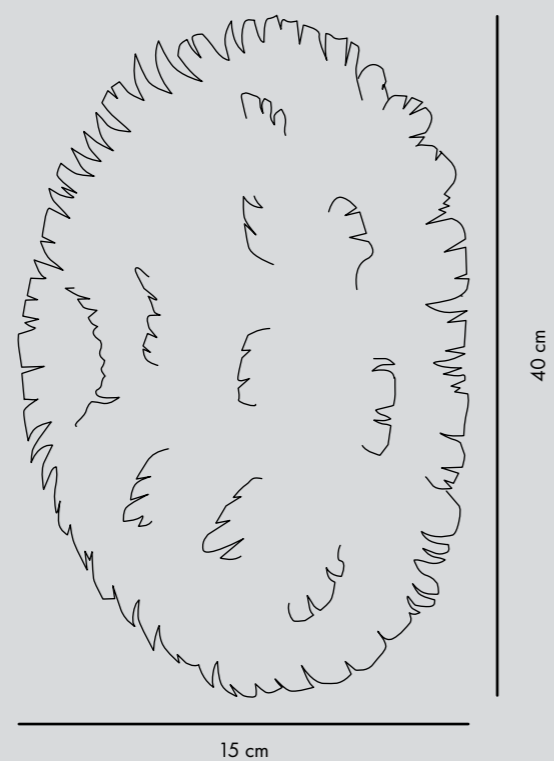



Eos Up | lamp

Item no. White 2140

 Materials Goose feathers

 Dimensions Ø: 40 x D: 15 cm

 Use Wall & Ceiling

 Light 2 x E27 / E26 - max 15 W LED

Designer Soren Ravn Christensen



Feather

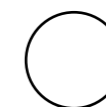

White
2140

“Silvia’s stylish and exquisite shape makes it the star of any environment”

Soren Ravn Christensen, Chief Creative Developer



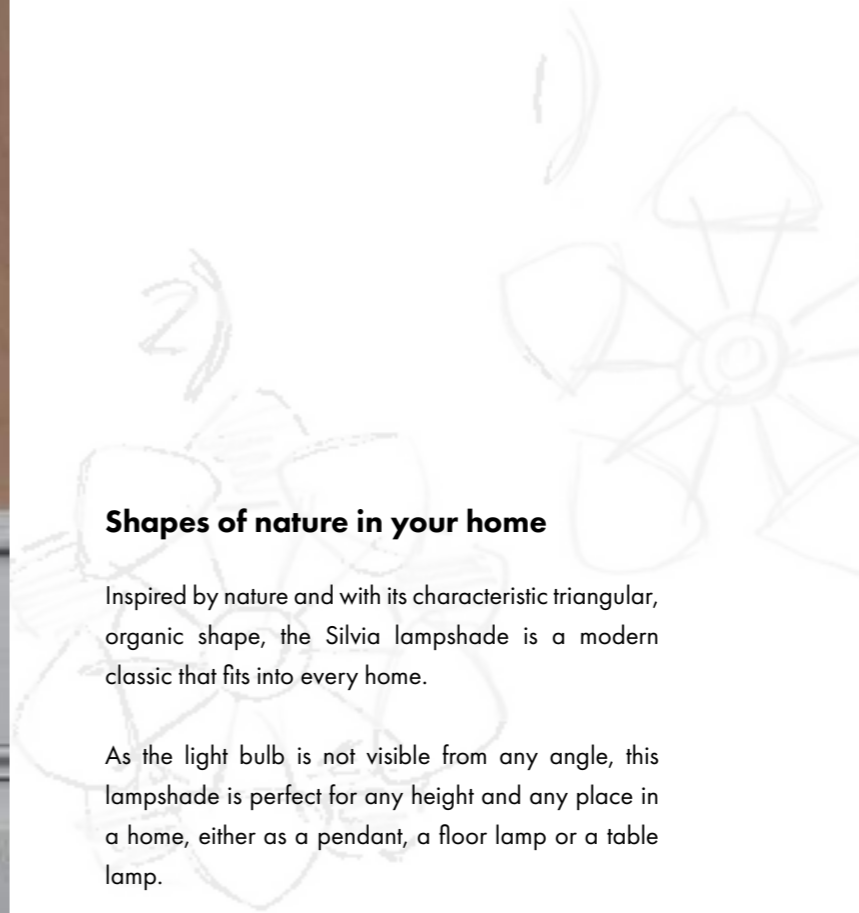

Shapes of nature in your home

Inspired by nature and with its characteristic triangular, organic shape, the Silvia lampshade is a modern classic that fits into every home.

As the light bulb is not visible from any angle, this lampshade is perfect for any height and any place in a home, either as a pendant, a floor lamp or a table lamp.

Available in a range of colours, Silvia delivers a warm and glare-free light.



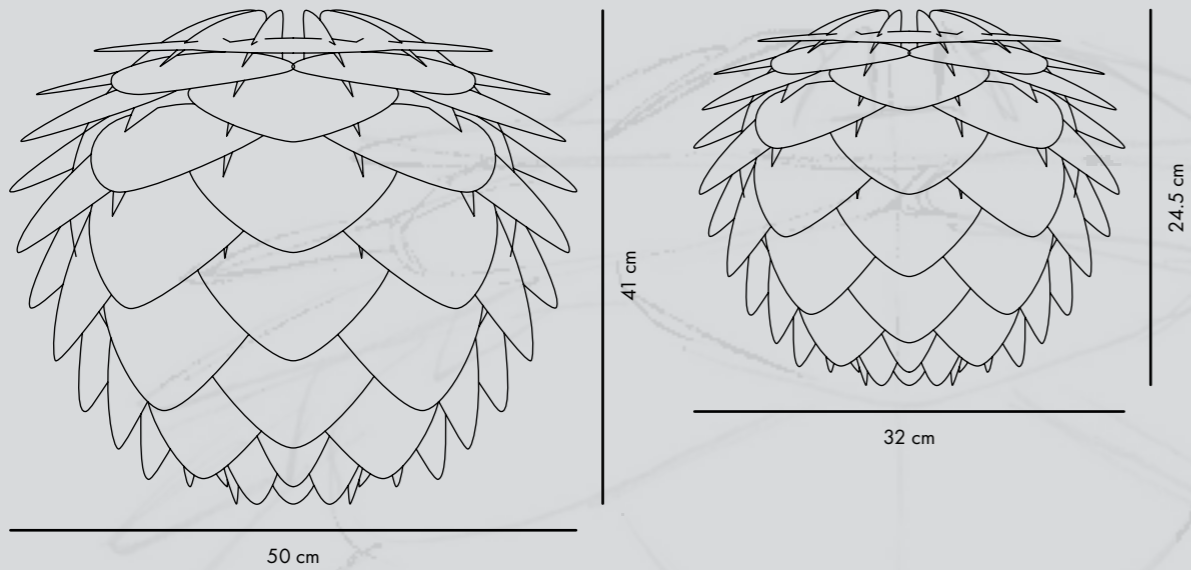



Silvia medium | lampshade

- # Item no. White 2007
 Copper 2030
 Brushed Steel 2053
 Brushed Brass 2070

 Materials Polypropylene

 Dimensions Ø: 50 x H: 41 cm

 Use Pendant, wall, floor & table lamp
Flip 180°

 Light E27 / E26 - max 15 W LED

Designer UIMAGE design team

Silvia mini | lampshade

- # Item no. White 2009
 Copper 2031
 Brushed Steel 2054
 Brushed Brass 2071

 Materials Polypropylene

 Dimensions Ø: 32 x H: 24.5 cm

 Use Pendant, wall, floor & table lamp
Flip 180°

 Light E27 / E26 - max 15 W LED

Designer UIMAGE design team

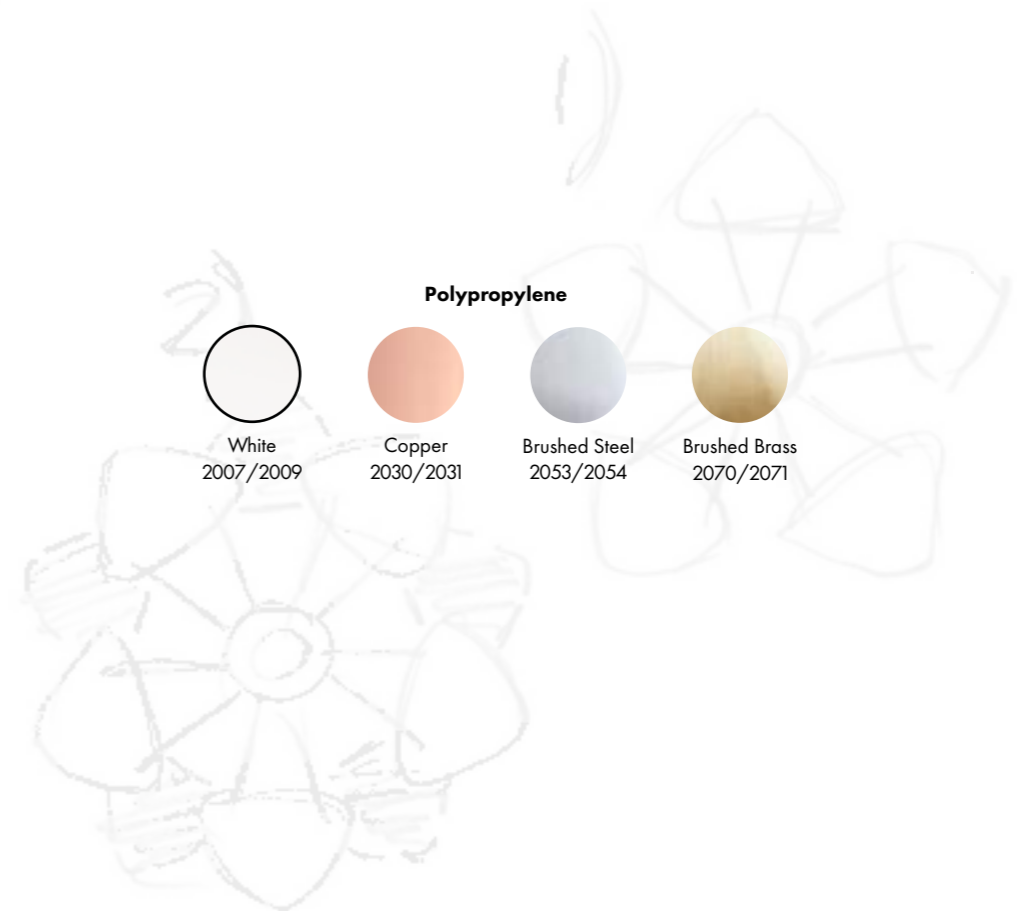
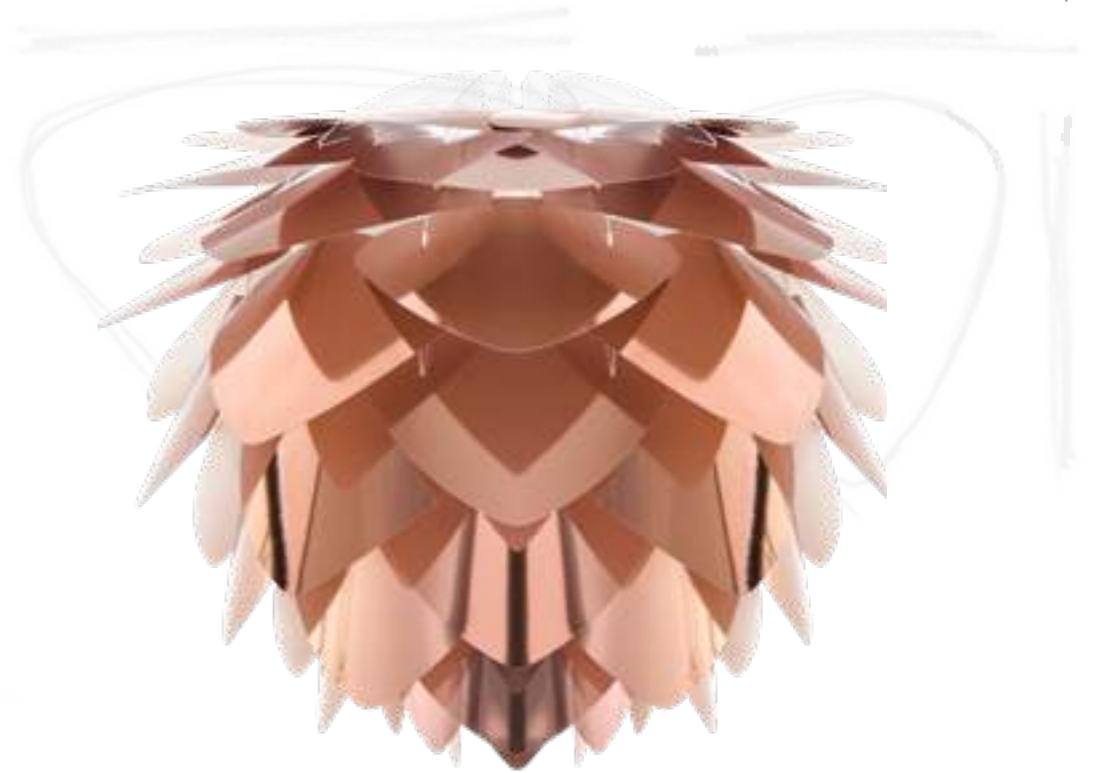

“Bring the beauty of nature inside”

Soren Ravn Christensen, Chief Creative Developer



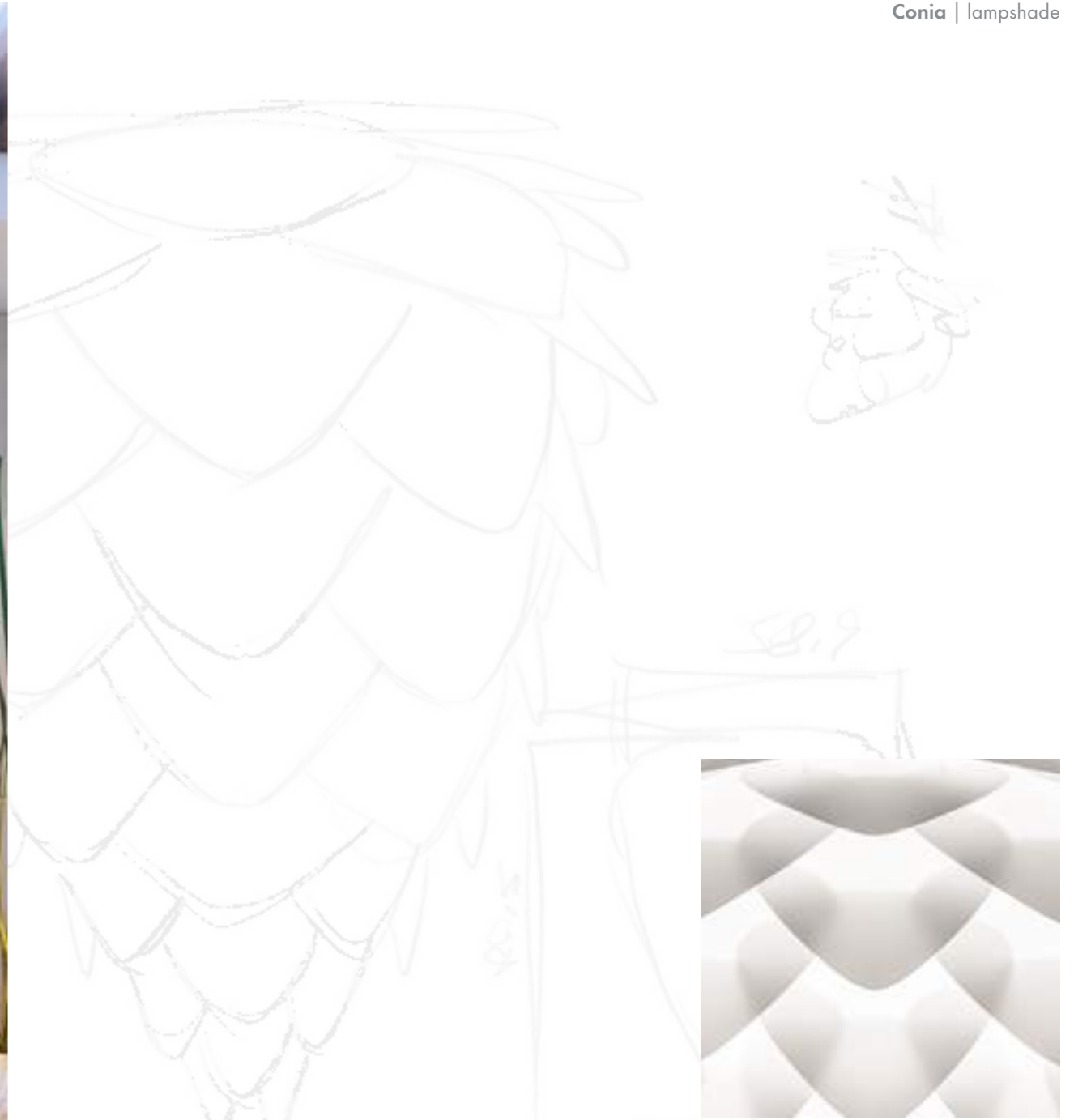

Illuminate your interior with iconic shapes

The Conia lampshade has a clear design reference to nature's beauty.

Its cone shape gives a soft and blind-free ambient light, making it a perfect artistic piece to illuminate every corner and dark spot in the house.

Conia is available in a range of colours, making it perfect for the living room, dining room or larger areas.

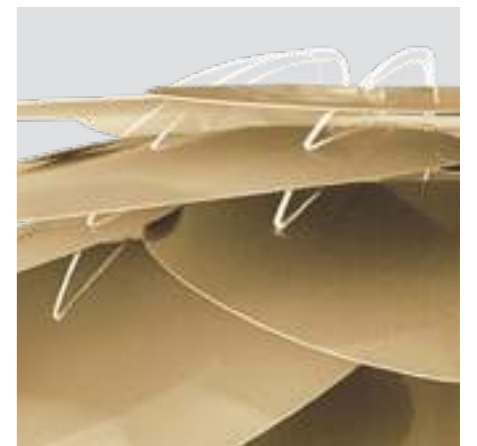

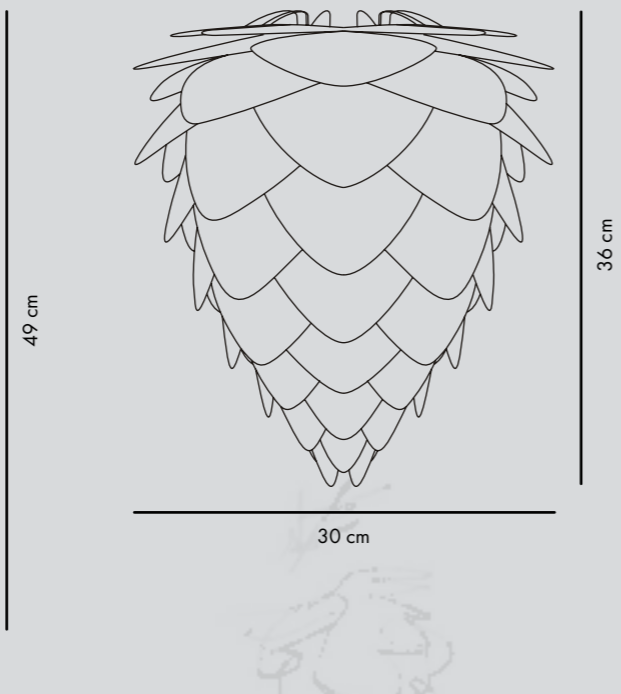



Conia medium | lampshade

- # Item no. White 2017
 Copper 2032
 Brushed Brass 2095

 Materials Polypropylene

 Dimensions Ø: 35 x H: 49 cm

 Use Pendant, wall, floor & table lamp
Flip 180°

 Light E27 / E26 - max 15 W LED

Designer Soren Ravn Christensen

Conia mini | lampshade

- # Item no. White 2019
 Copper 2033
 Brushed Brass 2096

 Materials Polypropylene

 Dimensions Ø: 30 x H: 36 cm

 Use Pendant, wall, floor & table lamp
Flip 180°

 Light E27 / E26 - max 15 W LED

Designer Soren Ravn Christensen

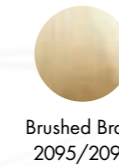
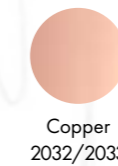

Polypropylene

White
2017/2019

Copper
2032/2033

Brushed Brass
2095/2096

**“Light up your surroundings
with dancing dots”**

Soren Ravn Christensen, Chief Creative Developer





Retro and exclusive in one lampshade

Clava is a small and stylish lampshade with an unforgettable shape and retro hints.

A series of small symmetrical holes adds an almost industrial look to the interior.

The Clava lampshade is ideal in the kitchen or dining area and works perfectly when hung in clusters.

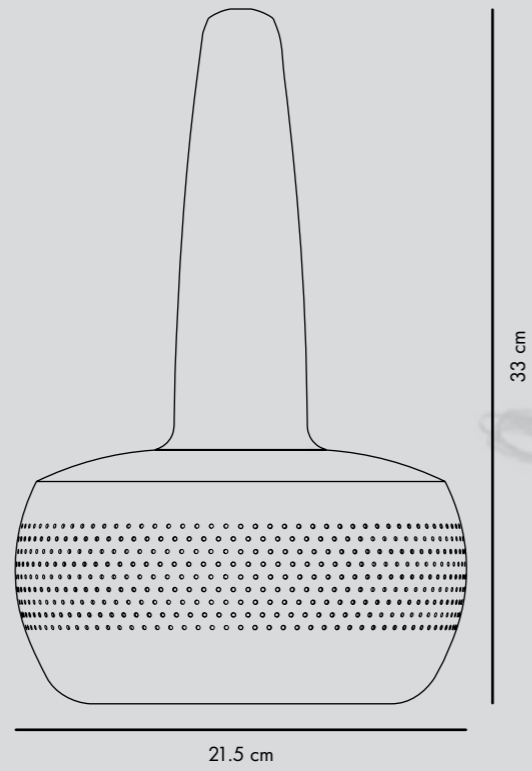

Clava | lampshade

- # Item no. Matte White 2051
 Brushed Copper 2111
 Polished Steel 2110
 Brushed Brass 2112

 Materials Aluminium

 Dimensions Ø: 21.5 x H: 33 cm

 Use Pendant

 Light E27 / E26 - max 15 W LED

Designer Soren Ravn Christensen



Aluminium



Matte White
2051



Brushed Copper
2111



Polished Steel
2110

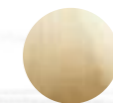

Brushed Brass
2112

“Clava Dine is all about the calm and majestic feelings of a memorable dinner”

Soren Ravn Christensen, Chief Creative Developer





Exclusive and cosy at the same time

The Clava Dine lampshade has a graceful silhouette and perforated holes giving it an industrial and retro feel.

With its exclusive and elegant look, Clava Dine fits perfectly over the dining or coffee table area, bringing a cosy and chic feel.

The lamp comes in a range of colours to light up your interior.

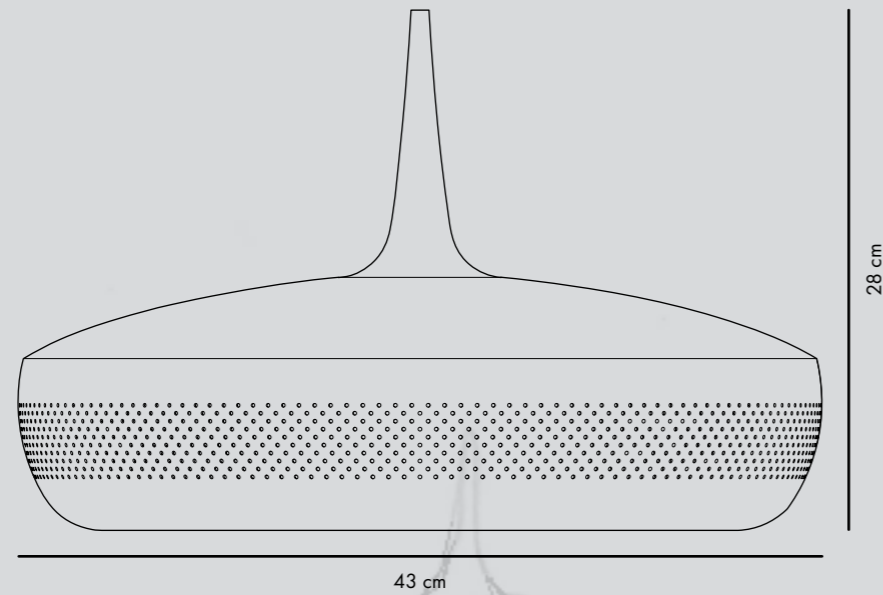

Clava Dine | lampshade

- # Item no. Matte White 2076
 Brushed Copper 2098
 Polished Steel 2097
 Brushed Brass 2099

 Materials Aluminium

 Dimensions Ø: 43 x H: 28 cm

 Use Pendant

 Light E27 / E26 - max 15 W LED

Designer Soren Ravn Christensen

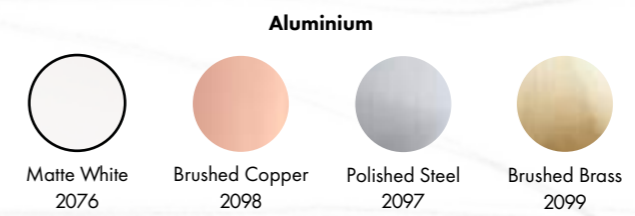



**“Discover the likeness
with your imagination”**

Jacob Rudbeck, Designer





Small but with a bright world inside

The Acorn lampshade combines a trendy glass look and raw metallic accents for an elegant finish that is just right for dining areas and restaurants.

The chic Acorn lampshade fits perfectly into small rooms and can also be used in beautiful clusters in bigger spaces.

Resembling the delicate nut, the Acorn lampshade consists of three parts: a soft silicone cup, a smooth outer shell of glass, and a kernel in a distinctive metallic finish.

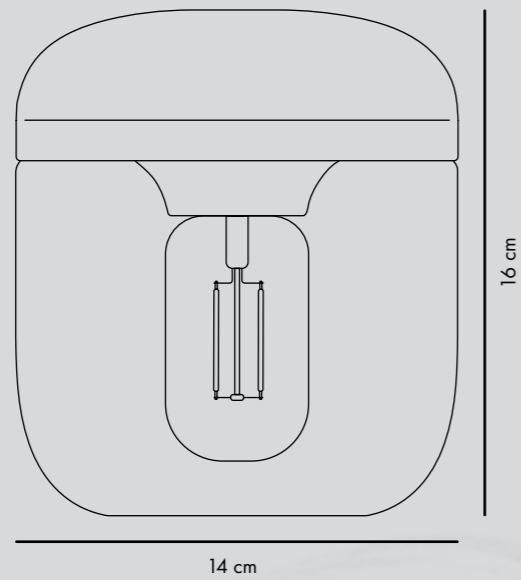

Acorn | lampshade

- # Item no.
- Black / Polished Steel 2081
 - Black / Polished Brass 2082
 - Black / Polished Copper 2083
 - White / Polished Steel 2104
 - White / Polished Brass 2105
 - White / Polished Copper 2106

M Materials Glass, Silicone & Aluminium

D Dimensions Ø: 14 x H: 16 cm

U Use Pendant

L Light E27 / E26 - max 15 W LED

Designer Jacob Rudbeck

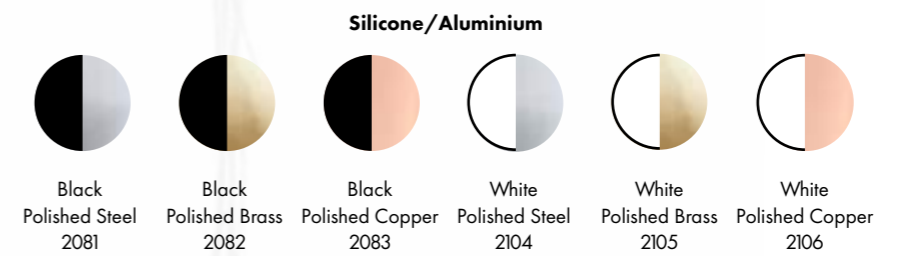



**“To get the perfect light,
you need the perfect shade”**

Soren Ravn Christensen, Chief Creative Developer



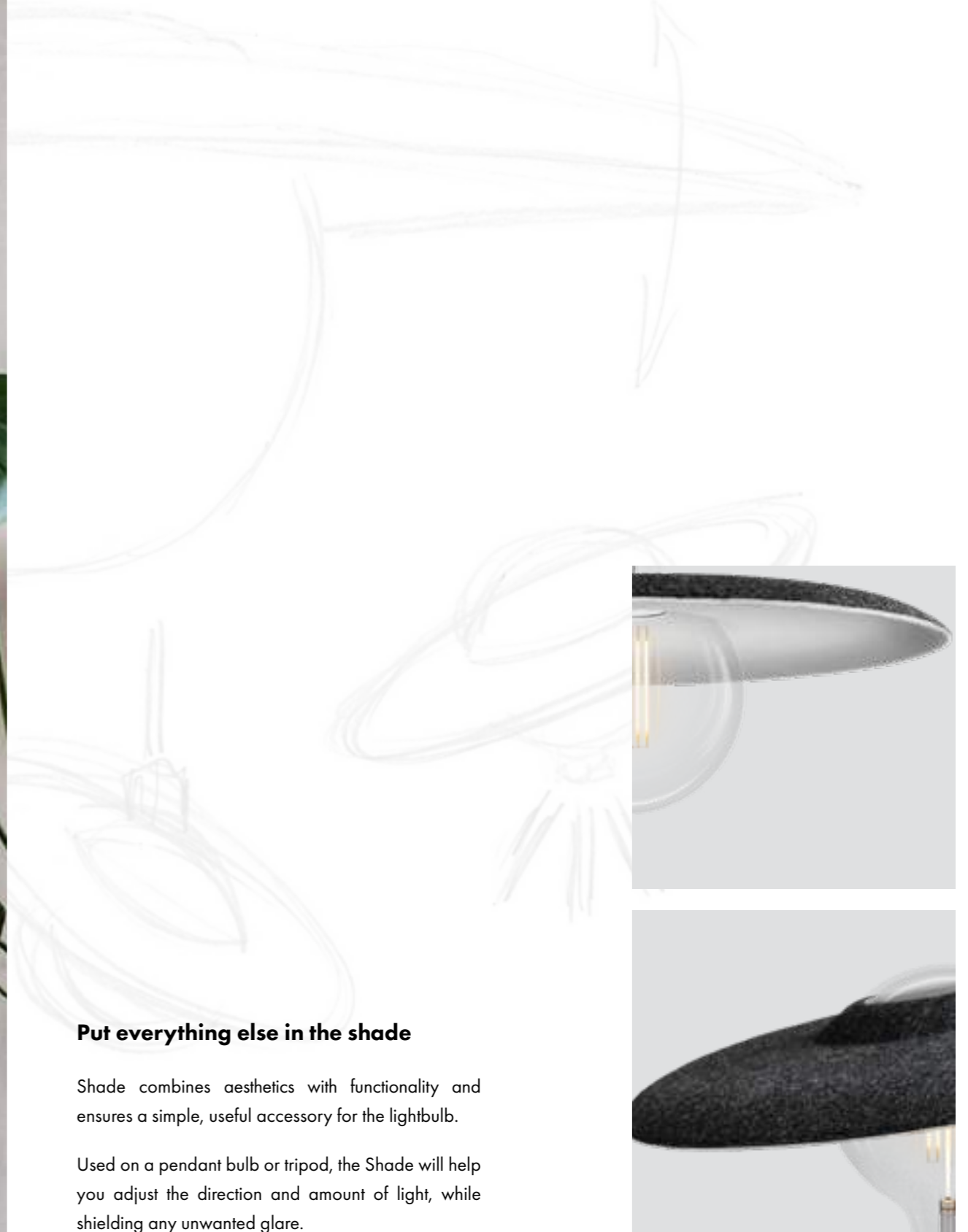

Put everything else in the shade

Shade combines aesthetics with functionality and ensures a simple, useful accessory for the lightbulb.

Used on a pendant bulb or tripod, the Shade will help you adjust the direction and amount of light, while shielding any unwanted glare.

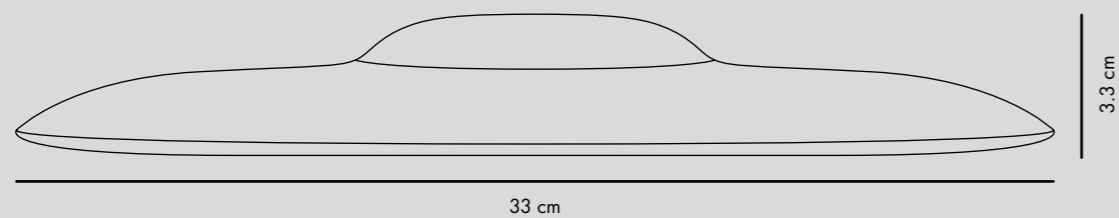

Shade | lampshade

Item no. ● Felt Grey 2107

Materials Felt

Dimensions Ø: 33 x H: 3.3 cm

Use Pendant, wall, floor & table lamp

Light E27 / E26 - max 15 W LED

Designer Soren Ravn Christensen



Felt



Felt Grey
2107

“The shape of Sine constantly alternates between symmetry and asymmetry, making it seem alive”

Miklos Leits, Designer





A lampshade that engages your sight and tactile senses

The Sine lampshade has a smooth layer of felt and a soft light that conveys a distinctive character and a cosy feel evocative of the Nordic style.

With an exclusive, yet playful design, and a completely glare-free glow, the Sine lampshade is suitable for all sorts of interiors.



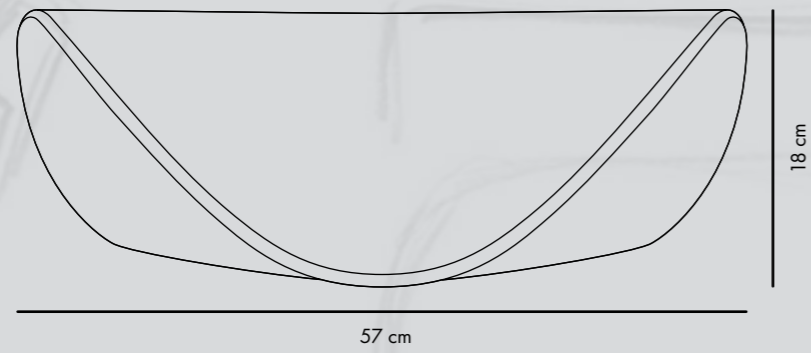
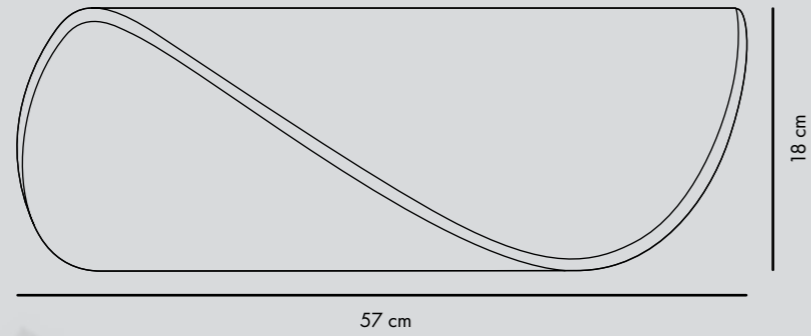

Sine | lampshade

Item no. ● Felt Grey 2084

Materials Felt & Polypropylene

Dimensions Ø: 57 x H: 18 cm

Use Pendant & wall lamp

Light E27 / E26 - max 15 W LED

Designer Miklos Leits

Felt

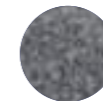

Felt Grey
2084

“Create just the right atmosphere anytime of day”

Soren Ravn Christensen, Chief Creative Developer
& Anders Klem, Designer



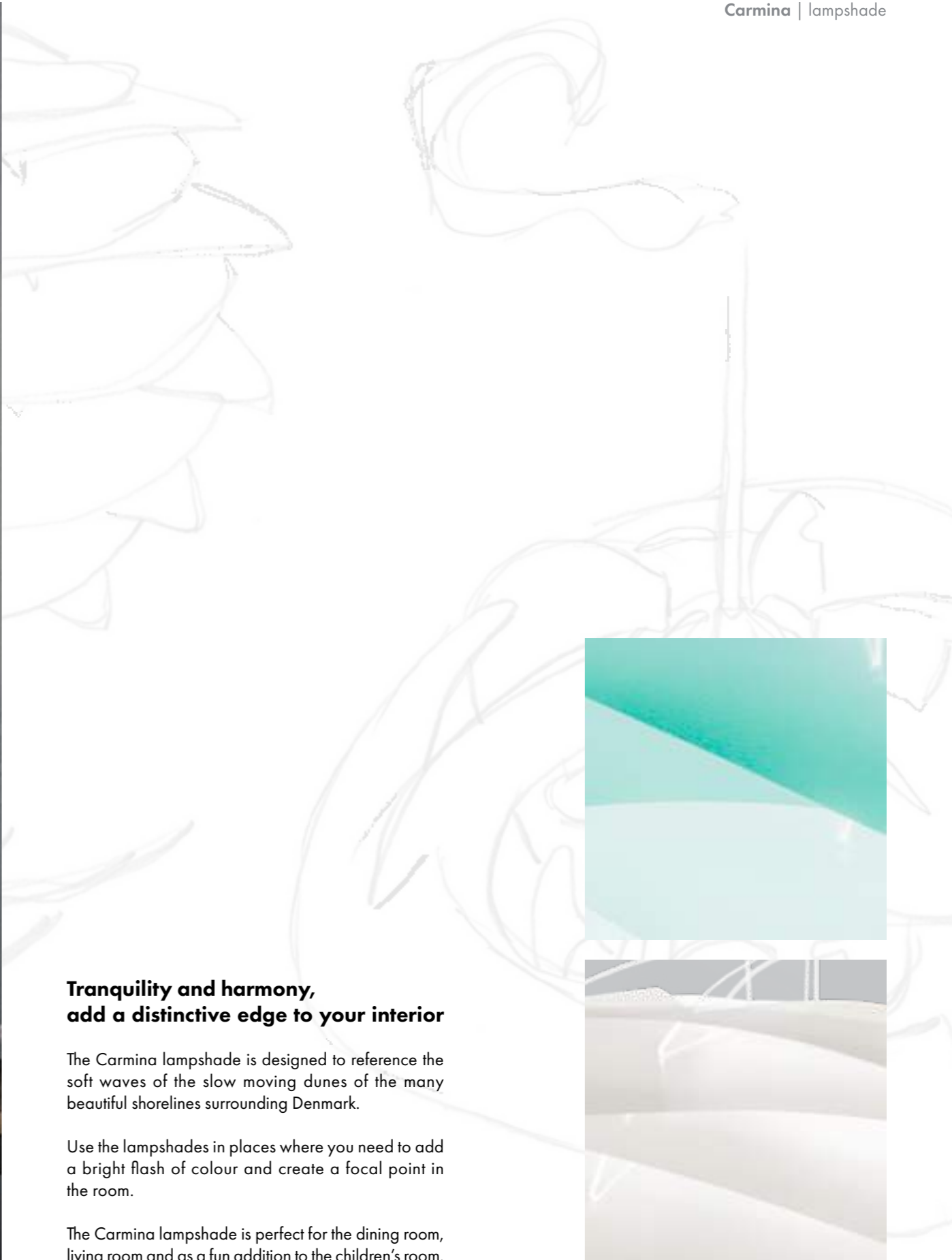

**Tranquility and harmony,
add a distinctive edge to your interior**

The Carmina lampshade is designed to reference the soft waves of the slow moving dunes of the many beautiful shorelines surrounding Denmark.

Use the lampshades in places where you need to add a bright flash of colour and create a focal point in the room.

The Carmina lampshade is perfect for the dining room, living room and as a fun addition to the children's room.



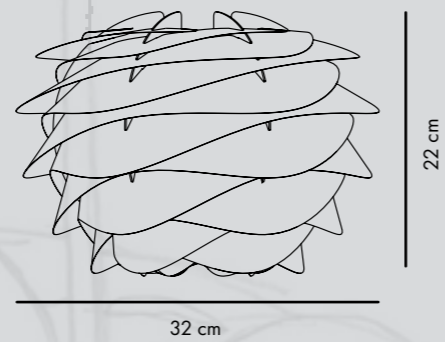
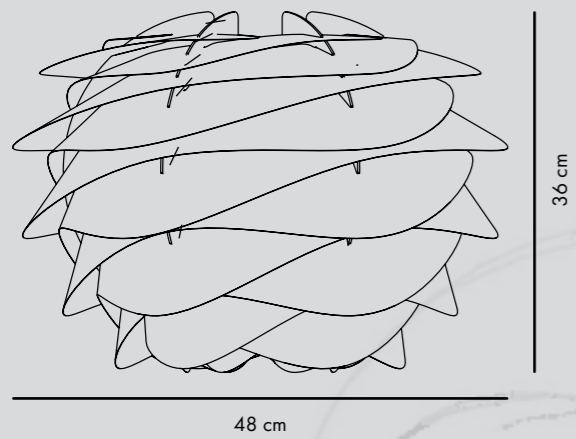

Carmina medium | lampshade

Item no. ○ White 2056

Materials Polypropylene

Dimensions Ø: 48 x H: 36 cm

Use Pendant & floor lamp

Light E27 / E26 - max 15 W LED

Designers Soren Ravn Christensen
Anders Klem

Carmina mini | lampshade

- # Item no. ○ White 2057
● Turquoise 2059
● Azure 2061
● Sahara 2063
● Misty Grey 2079
● Baby Rose 2080

Materials Polypropylene

Dimensions Ø: 32 x H: 22 cm

Use Pendant, wall-, floor- & table lamp

Light E27 / E26 - max 15 W LED

Designers Soren Ravn Christensen
Anders Klem

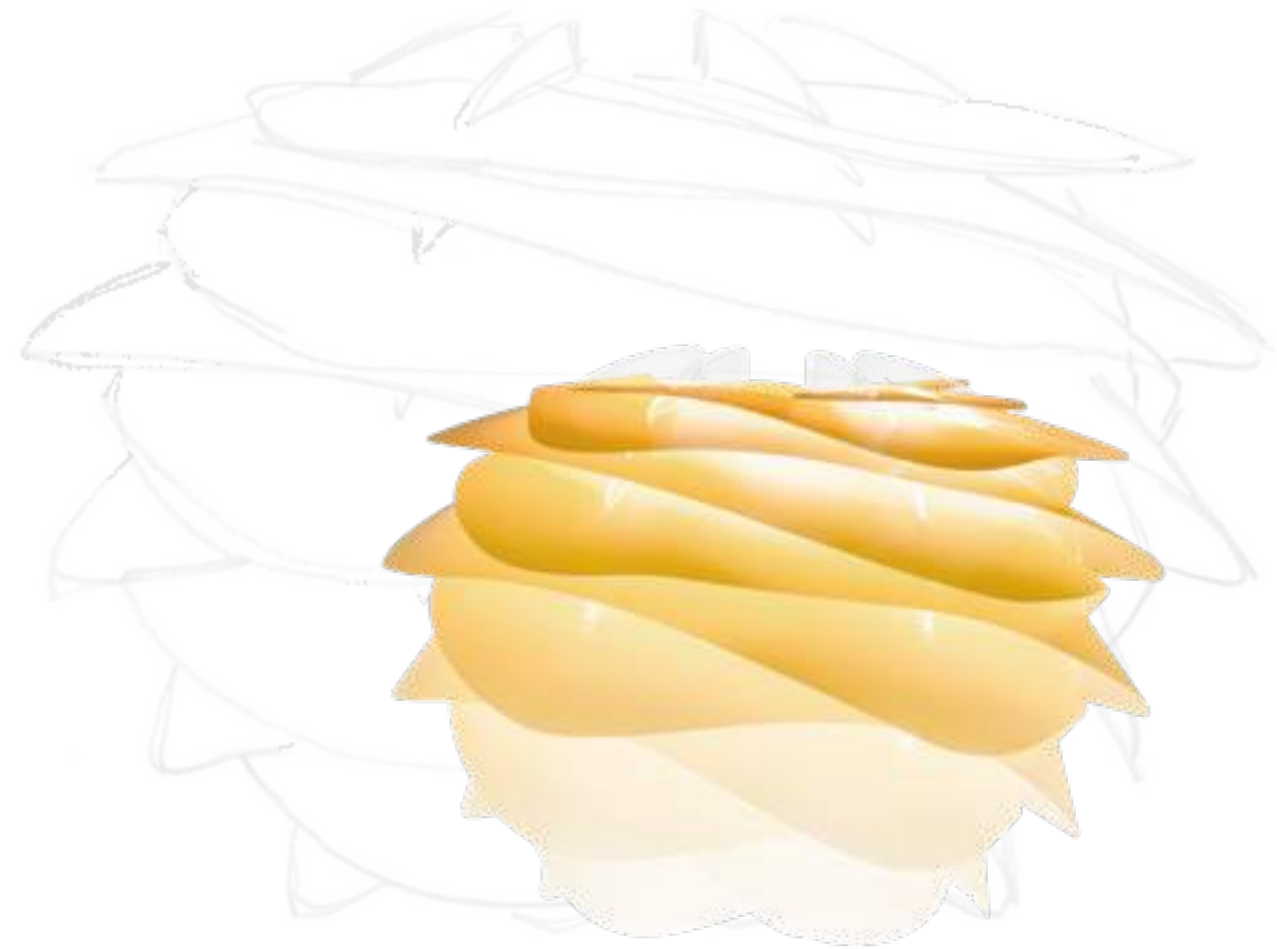

Polypropylene



White
2056/2057



Turquoise
2059



Azure
2061



Sahara
2063

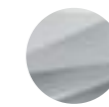

Misty Grey
2079



Baby Rose
2080

**“Let Alva’s curvy lines of light
seduce you”**

Lorenzo Radaelli, Designer



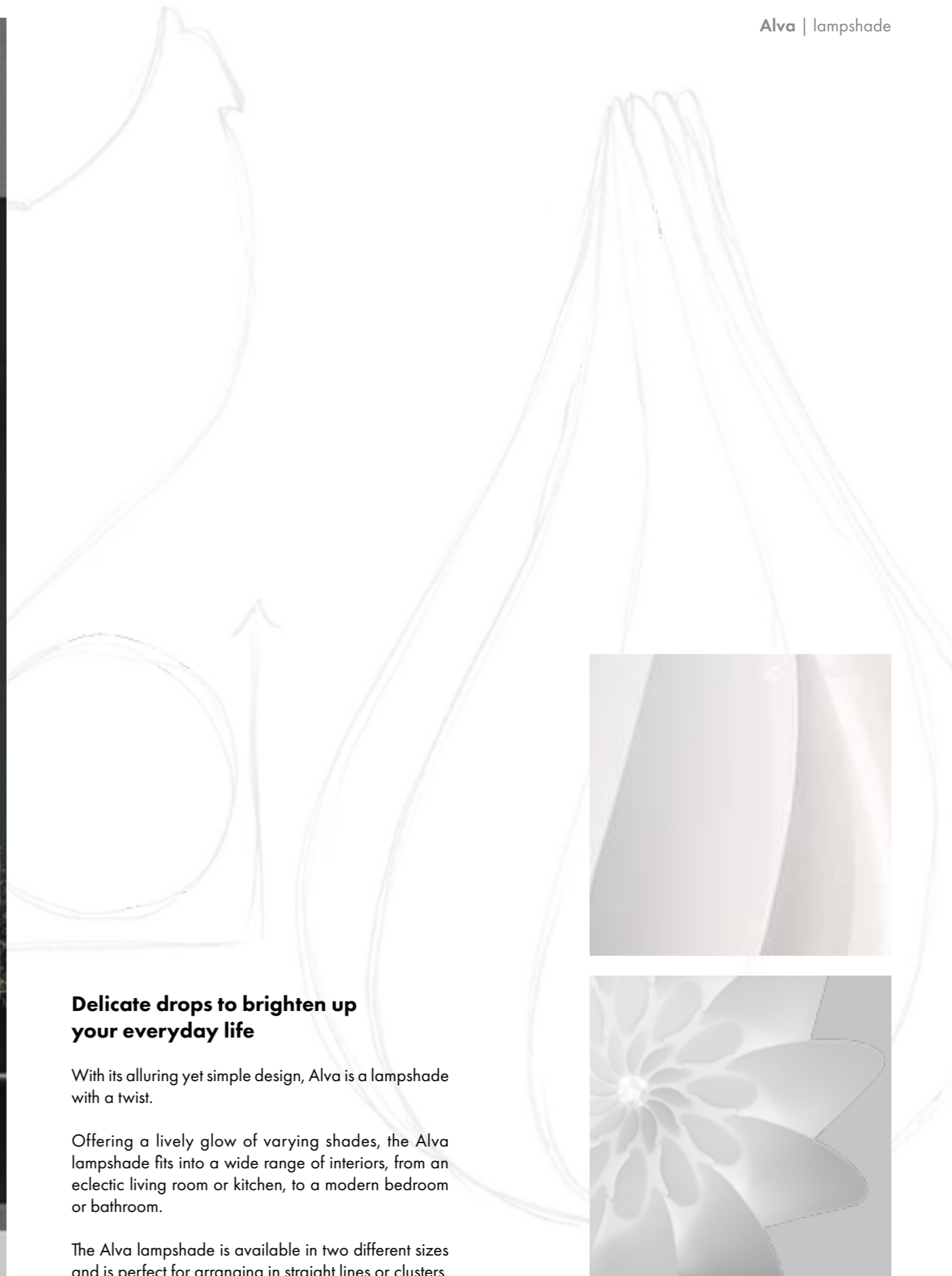

Delicate drops to brighten up your everyday life

With its alluring yet simple design, Alva is a lampshade with a twist.

Offering a lively glow of varying shades, the Alva lampshade fits into a wide range of interiors, from an eclectic living room or kitchen, to a modern bedroom or bathroom.

The Alva lampshade is available in two different sizes and is perfect for arranging in straight lines or clusters.

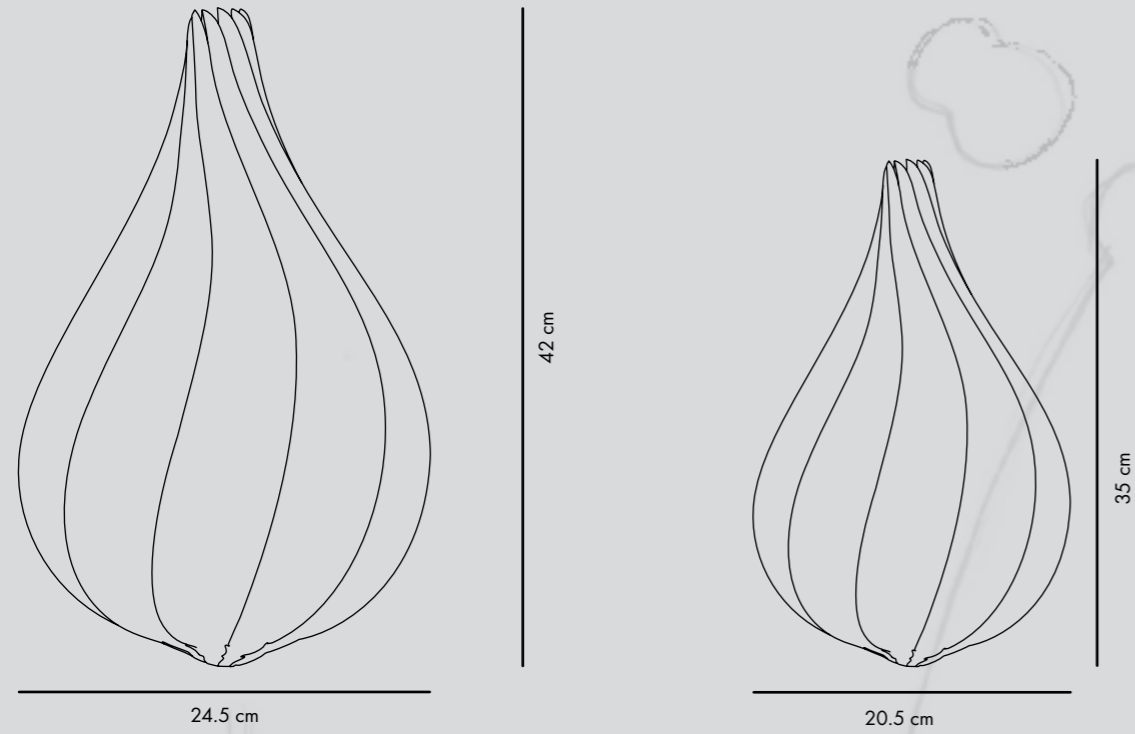



Alva medium | lampshade

Item no. White 2102

 Materials Polypropylene

 Dimensions Ø: 24.5 x H: 42 cm

 Use Pendant

 Light E27 / E26 - max 15 W LED

Designer Lorenzo Radaelli

Alva mini | lampshade

Item no. White 2103

 Materials Polypropylene

 Dimensions Ø: 20.5 x H: 35 cm

 Use Pendant

 Light E27 / E26 - max 15 W LED

Designer Lorenzo Radaelli



Polypropylene

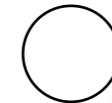

White
2102/2103

**“Defy gravity
and bring light to life”**

Soren Ravn Christensen, Chief Creative Developer



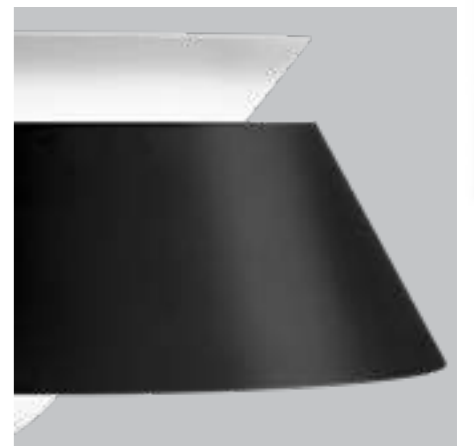
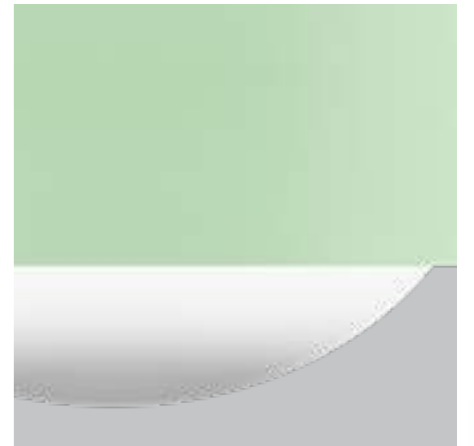

Timeless design in a modern sculpture

The Cuna lampshade combines sculptural details with soft diffuse lighting.

The lampshade has a clever construction and is made from powder coated steel with all of the parts connected without assembly; only gravity is in use.

The Cuna lampshade is a timeless Scandinavian piece of design that works well in an office or dining room.

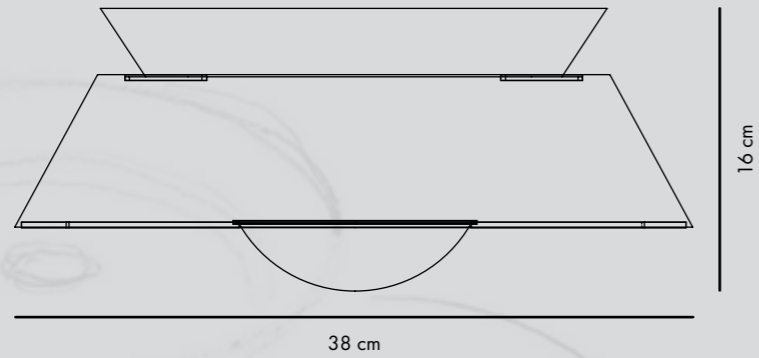

Cuna | lampshade

Item no. Matte White 2034
 Matte Black 2035
 Mint Green 2036

 Materials Steel

 Dimensions Ø: 38 x H: 16 cm

 Use Pendant

 Light E27 / E26 - max 15 W LED

Designers UIMAGE Design Team

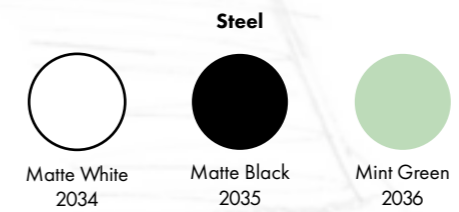

**“Explore the pattern
and discover new shapes”**

Lorenzo Radaelli, Designer





Put the pieces together in a perfect puzzle of light

The Lora lampshade resembles a sphere of flowers and has a clever design that leads your eyes around its round shape.

The Lora lampshade is made of almost 65 identical pieces that creates a multishaded light effect.

Lora can be used both as a pendant and floor lamp and is particularly suitable for the living room, bedroom or to liven up a dark corner.



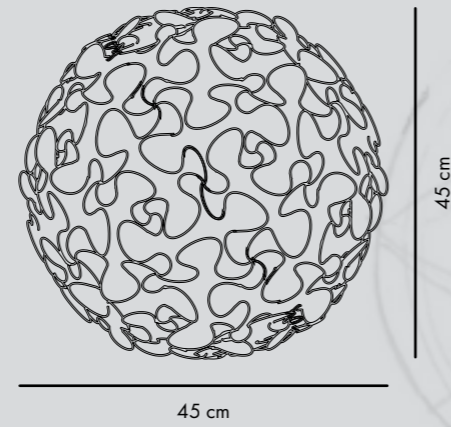
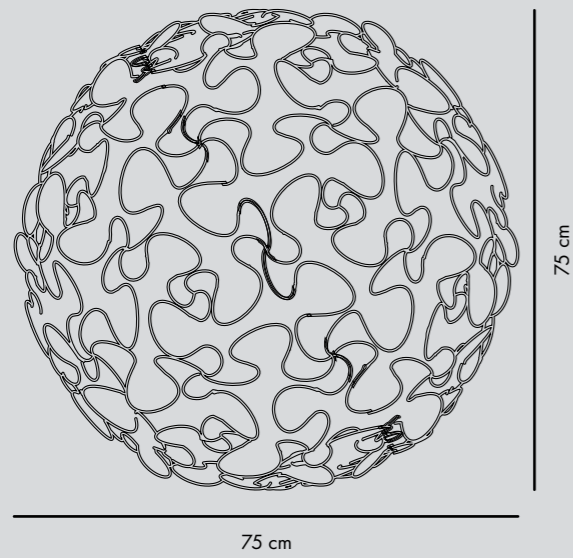



Lora x-large | lampshade

Item no. White 2065

 Materials Polypropylene

 Dimensions Ø: 75 x H: 75 cm

 Use Pendant & floor lamp

 Light E27 / E26 - max 15 W LED

Designer Lorenzo Radaelli

Lora medium | lampshade

Item no. White 2064

 Materials Polypropylene

 Dimensions Ø: 45 x H: 45 cm

 Use Pendant, wall-, floor- & table lamp

 Light E27 / E26 - max 15 W LED

Designer Lorenzo Radaelli



Polypropylene

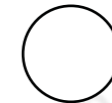

White
2065/2064

**"A creative canvas for
expressing your creativity"**

Soren Ravn Christensen, Chief Creative Developer



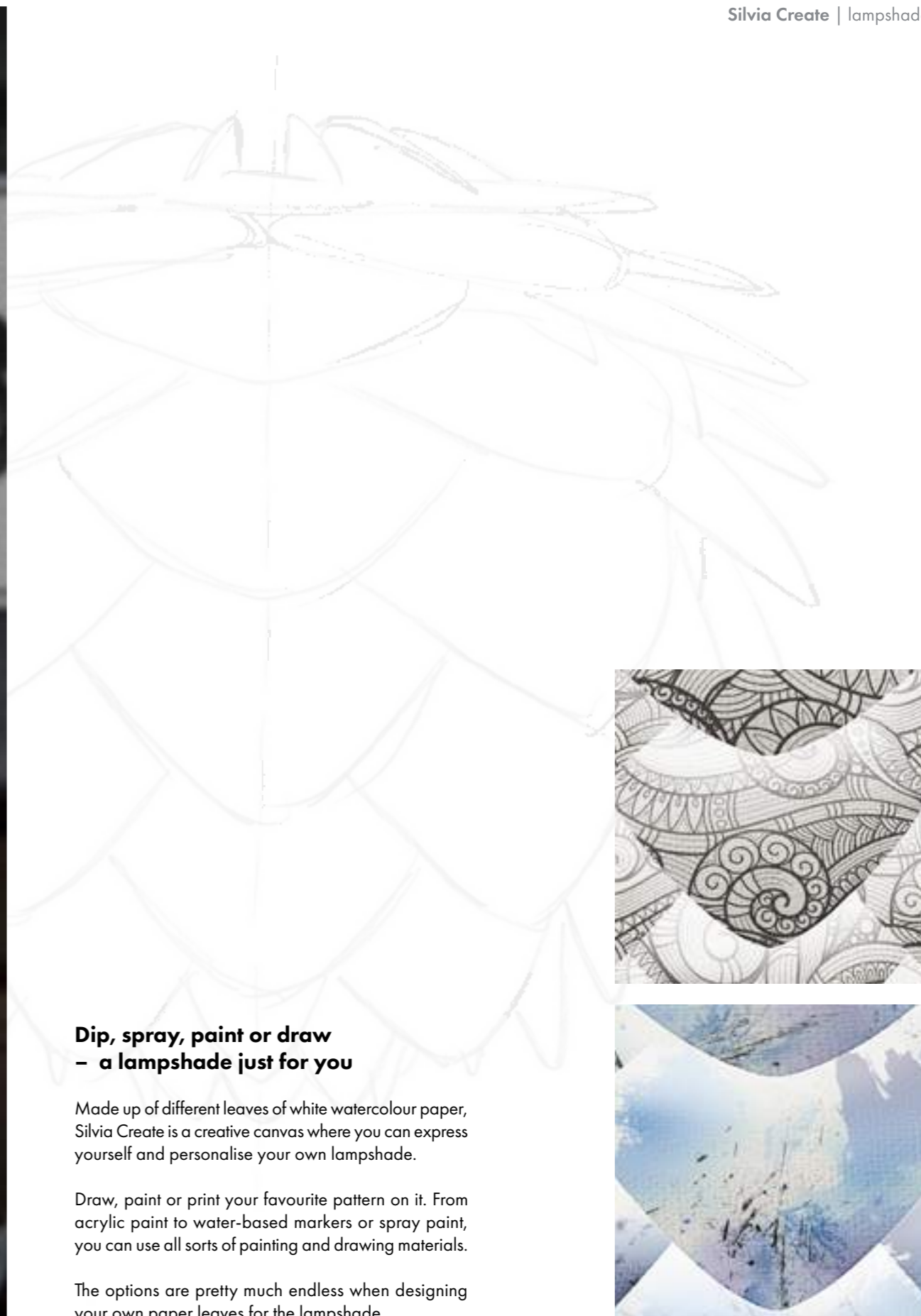

**Dip, spray, paint or draw
– a lampshade just for you**

Made up of different leaves of white watercolour paper, Silvia Create is a creative canvas where you can express yourself and personalise your own lampshade.

Draw, paint or print your favourite pattern on it. From acrylic paint to water-based markers or spray paint, you can use all sorts of painting and drawing materials.

The options are pretty much endless when designing your own paper leaves for the lampshade.

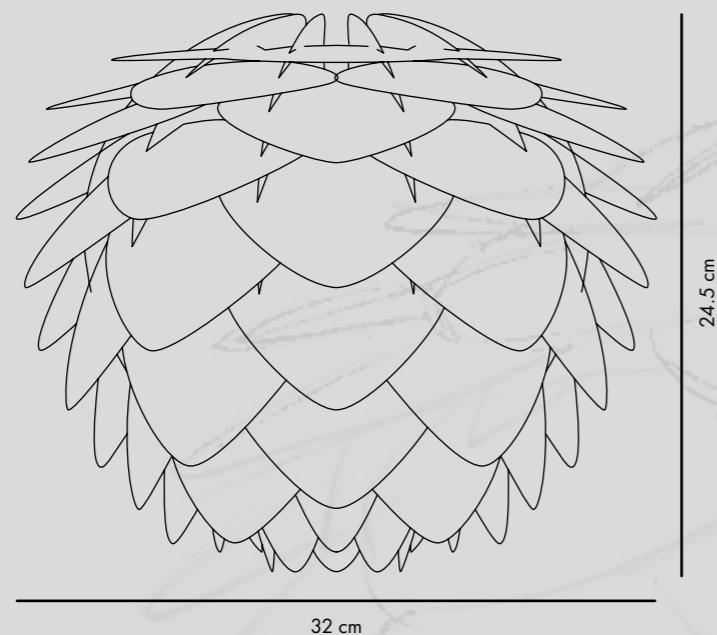

Silvia Create | lampshade

Item no. White 2100

 Materials Watercolour paper

 Dimensions Ø: 32 x H: 24.5 cm

 Use Pendant, wall-, floor- & table lamp
Flip 180° 

 Light E27 / E26 - max 15 W LED

Designers UIMAGE Design Team



Watercolour Paper



White
2100

**“Combine a modern appearance
with a classic design”**

Soren Ravn Christensen, Chief Creative Developer





**Ripples of light,
just where you need them**

The endless miles of coastline surrounding Scandinavia and the small waves formed by a soft breeze over the calm sea is the inspiration behind the Ripples lampshades.

The Ripples lampshades are available in three different shapes – the Slope, the Cusp and the Curve.

Either used in a straight line or in a random cluster, these minimalistic lamps will offer you just the right amount of light needed for that special evening.

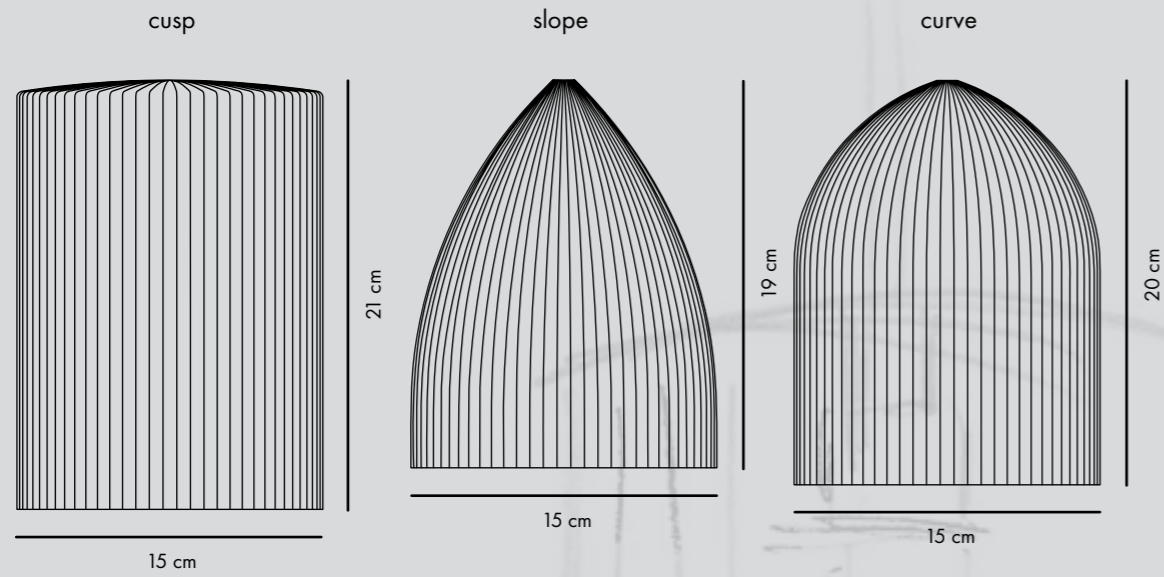

Ripples | lampshades

# Item no.	Cusp 2043 Slope 2044 Curve 2045
M Materials	Silicone & Polypropylene
D Dimensions	Ø: 15 x H: 19-21 cm
U Use	Pendant
L Light	E27 / E26 - max 15 W LED
Designer	Soren Ravn Christensen



ACCESSORIES





**“Just where you need to create that
tranquil flickering candlelight atmosphere”**

Soren Ravn Christensen, Chief Creative Developer



Tripod floor | black



Tripod table | black



Tripod base | white



Stand up for lampshades

Tripod light stands are available in three sizes, ready to turn your favourite lampshades into a perfect table or floor lamp.

The smaller Tripod base is an adjustable 2-in-1 tripod for your table lampshade that can be placed in a high or low position.

The bold and minimalistic design of the Tripod light stands has a clever construction that allows you to assemble them in no time at all.



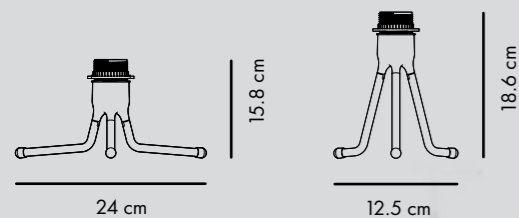

Tripod base | lighting stand

Item no. White 4053 Black 4054

Materials Aluminium

Dimensions Ø: 24 x H: 15.8 cm
Ø: 12.5 x H: 18.6 cm

Use Table lamp. Flip legs 180°

Light E27 / E26 - max 15 W LED

Designer Soren Ravn Christensen

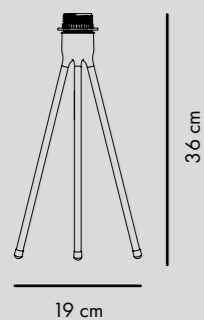

Tripod table | lighting stand

Item no. White 4021 Black 4022

Materials Aluminium

Dimensions Ø: 19 x H: 36 cm

Use Table lamp

Light E27 / E26 - max 15 W LED

Designer Soren Ravn Christensen

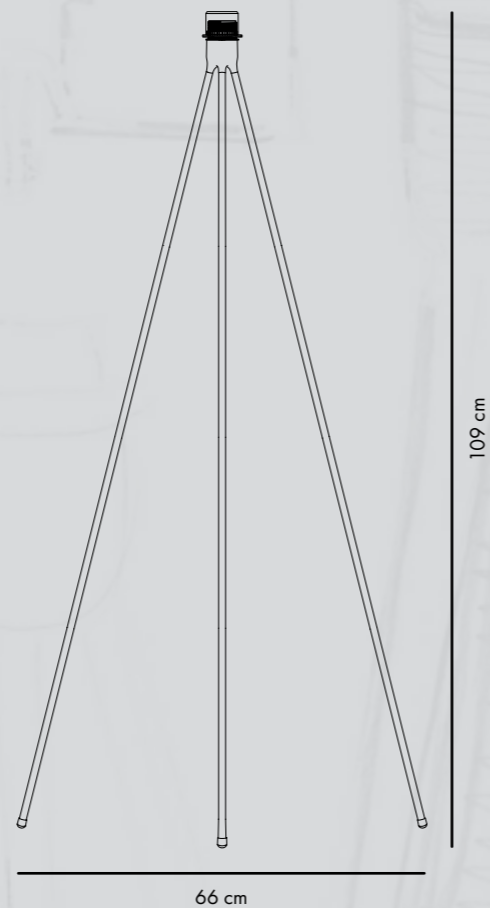

Tripod floor | floor lamp base

Item no. White 4015 Black 4016

Materials Aluminium

Dimensions Ø: 66 x H: 109 cm

Use Floor lamp

Light E27 / E26 - max 15 W LED

Designer Soren Ravn Christensen

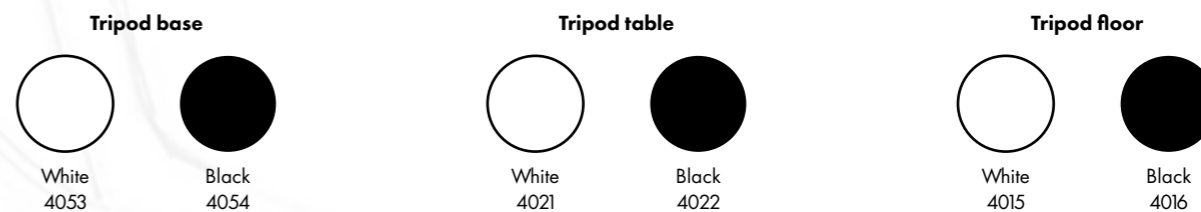
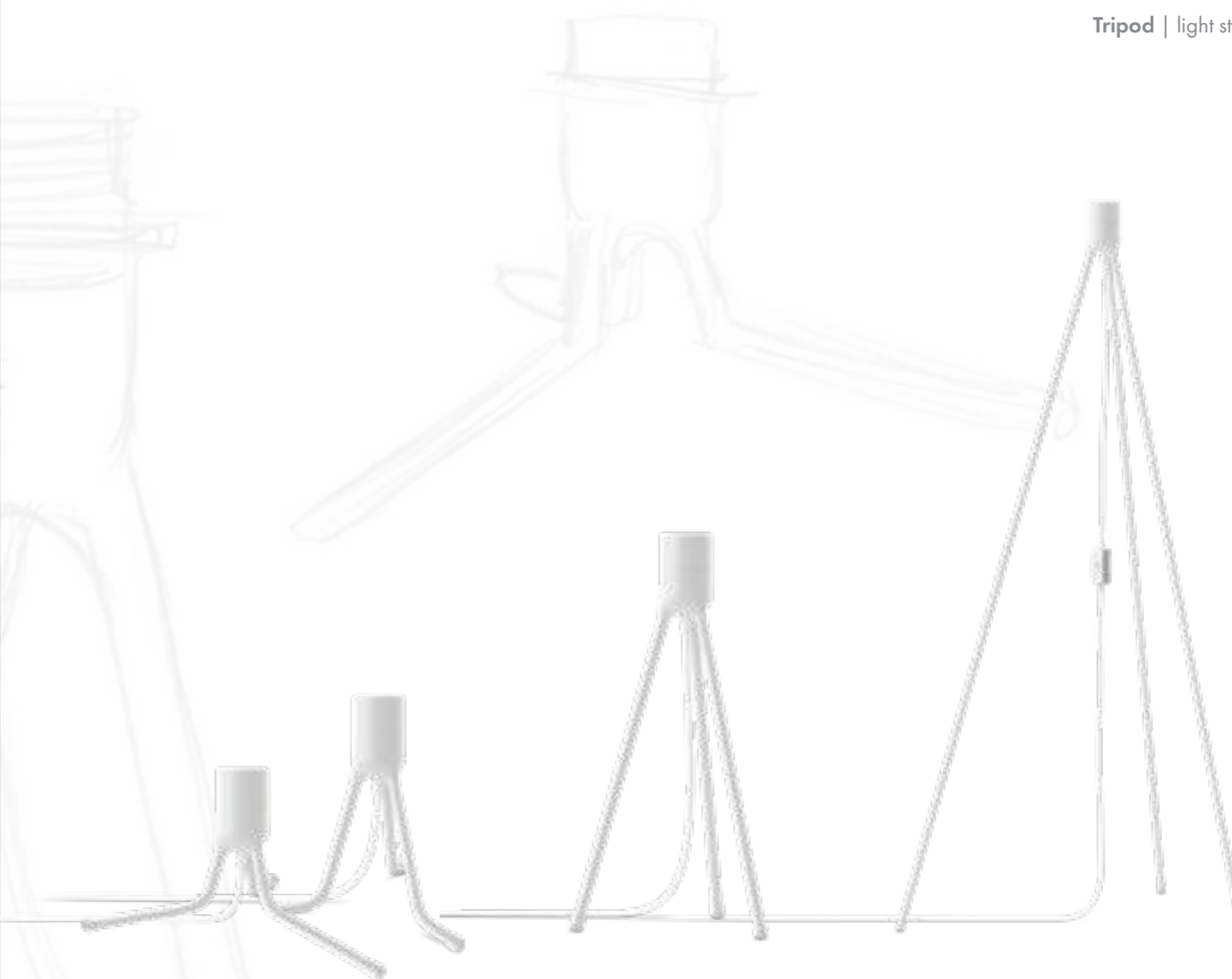

“Practical cosiness, at its best! Just place it near the bed, behind the couch, in a corner or anywhere you need to add extra light”

Soren Ravn Christensen, Chief Creative Developer

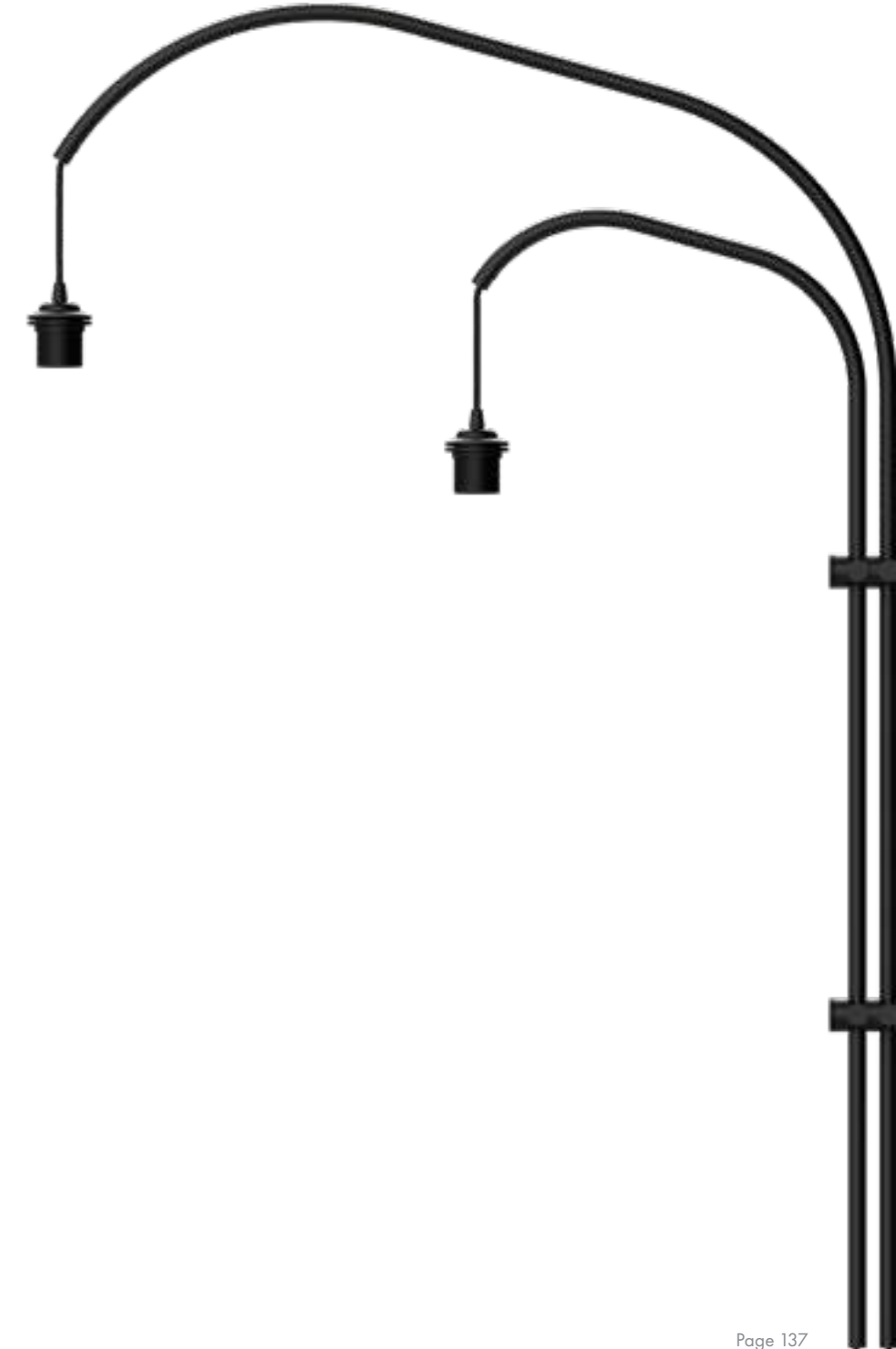

Willow single | white



Willow mini | white



Willow double | white



**Lamps on the wall,
just where you need them**

With their subtle and minimal design, the Willow and Willow mini wall light stands let you mount a pendant lamp without having to install extra electric cables inside your wall or ceiling.

Minimalistic and simple, Willow and Willow mini work with all sorts of lampshades.

Remove clutter from the room and easily attach more lamps directly on the wall wherever you choose.

Use the Willow and Willow mini wall light stands for hanging a reading lamp besides the bed or as a part of a reading corner next to the sofa.



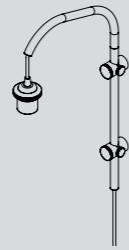

Willow mini | wall light stand

Item no. White 4150
 Black 4151

Materials Aluminium & steel

Dimensions H: 50.1 x D: 29.8 cm

Use Wall lamp

Light E27 / E26 - max 15 W LED

Designer Soren Ravn Christensen

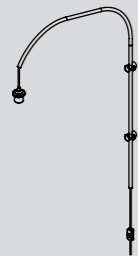

Willow single | wall light stand

Item no. White 4110
 Black 4111

Materials Aluminium & steel

Dimensions H: 123 x D: 77.7 cm

Use Wall lamp

Light E27 / E26 - max 15 W LED

Designer Soren Ravn Christensen

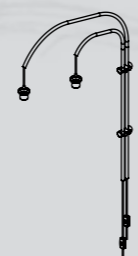

Willow double | wall light stand

Item no. White 4130
 Black 4131

Materials Aluminium & steel

Dimensions H: 123 x D: 40/77.7 cm

Use Wall lamp

Light E27 / E26 - max 15 W LED

Designer Soren Ravn Christensen

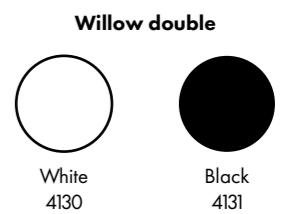
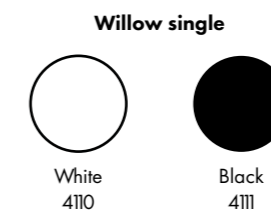
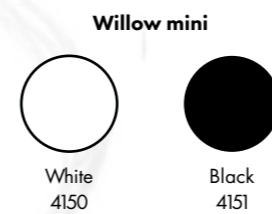

**“There is always the one that with quiet grace
and elegance draws our eyes, without even trying”**

Anders Klem, Designer



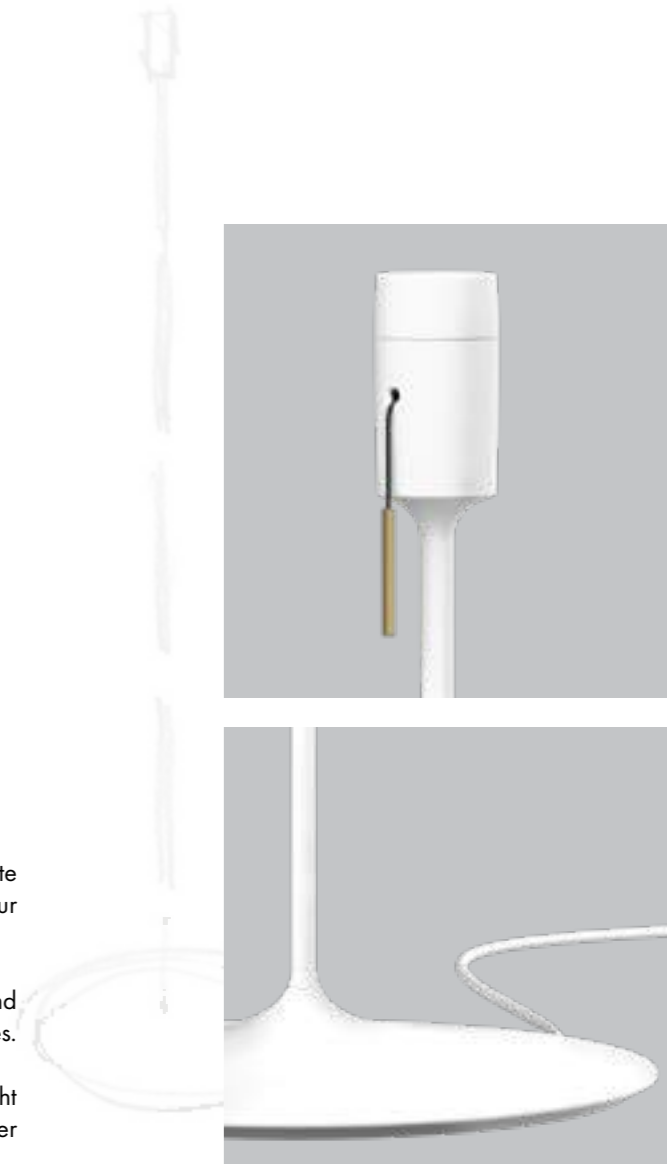

An elegant accompaniment to your everyday celebrations

The Champagne light stand is inspired by the delicate glamour of a champagne glass and lets you use your lampshades in all sorts of new settings.

The stainless-steel pull switch of the Champagne stand adds a distinctive edge to its clean and minimalistic lines.

Available in both black and white, the Champagne light stand has a sturdy base and can be paired with either a stylish lampshade or a trendy light bulb.

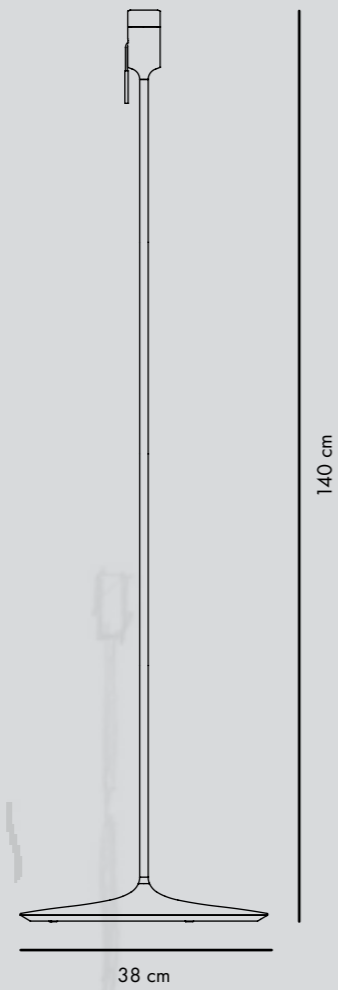



Champagne | lighting stand

Item no. White 4035
 Black 4036

 Materials Aluminium, steel, MDF & ABS

 Dimensions Ø: 38 x H: 140 cm

 Use Floor lamp

 Light E27 / E26 - max 15 W LED

Designer Soren Ravn Christensen

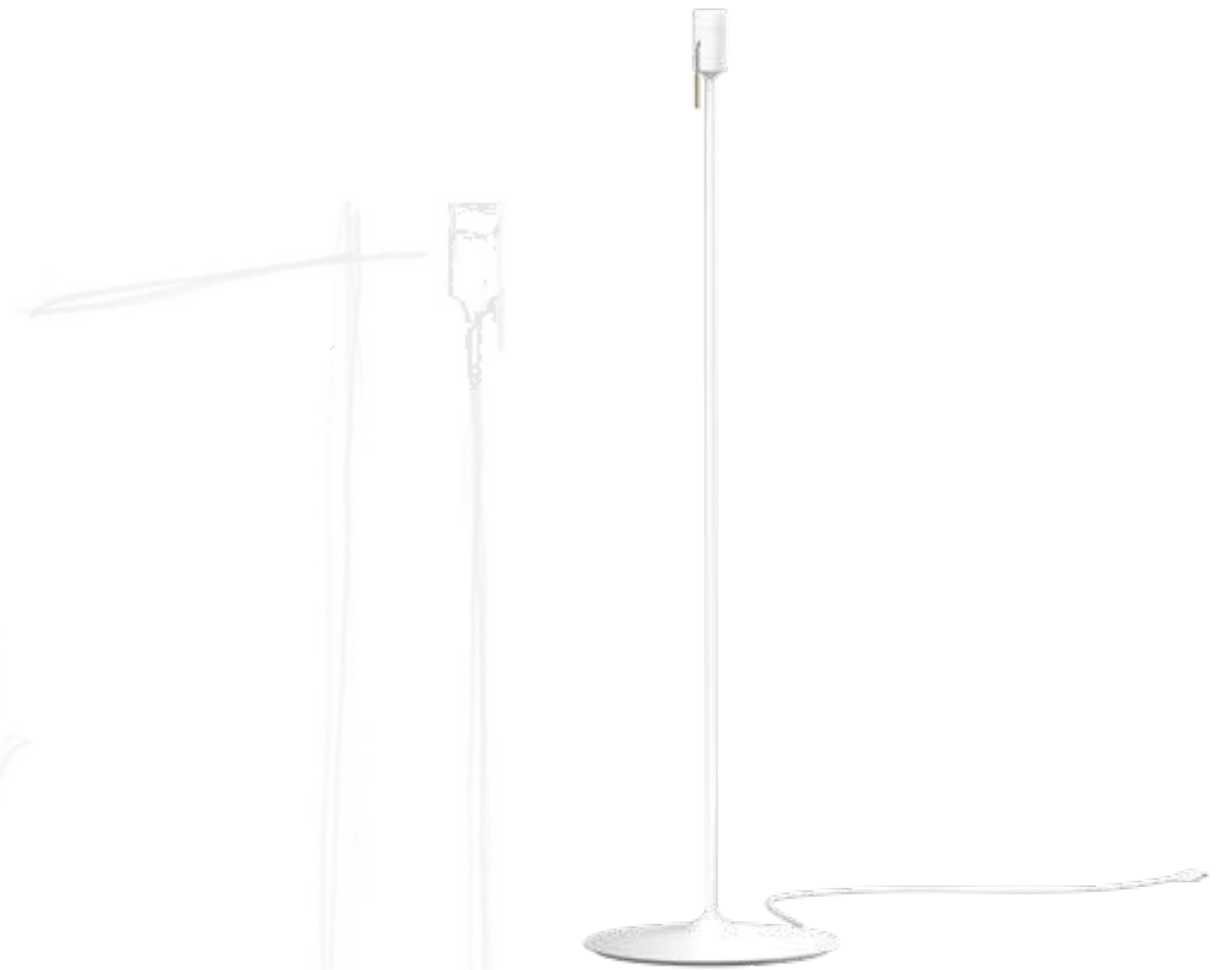

Champagne

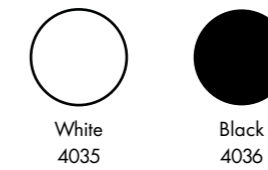

“What’s a lampshade without lightbulbs and cords?”

Soren Ravn Christensen, Chief Creative Developer

Find the right lighting accessory to complete the look

With a focus on functionality and design, our range of lightbulbs, canopies and cords have been created as perfect accompaniments to your lampshades.

Our lightbulbs offer a range of moods from a pleasant warm glow for a cosy and relaxed ambience to a soft white light for a brighter mood.

Our canopies and cords have a discreet and organic look that allow you to hang your pendant lampshades on their own or in clusters.





Rosette | canopy

Item no. White 4144
 Black 4145

Materials Metal. 2.1 m textile cord.

Dimensions Ø: 14 cm

Use Pendant

Light E27 / E26 - max 15 W LED

Designer UIMAGE Design Team



Cord set | canopy

Item no. White 4005
 Black 4006

Materials Plastic. 2.1 m textile cord.

Dimensions Ø: 11 cm

Use Pendant

Light E27 / E26 - max 15 W LED

Designer UIMAGE Design Team



Cannonball | canopy

Item no. White 4031
 Black 4032

Materials Silicone. 2.5 m textile cord.

Dimensions Ø: 12 cm

Use Pendant

Light E27 / E26 - max 15 W LED

Designer Soren Ravn Christensen



Cannonball cluster 2 | canopy

Item no. White 4089
 Black 4091

Materials Silicone. 2.5 m textile cord.

Dimensions Ø: 12 cm

Use Pendants

Light E27 / E26 - max 15 W LED

Designer Soren Ravn Christensen



Cannonball cluster 3 | canopy

Item no. White 4090
 Black 4092

Materials Silicone. 2.5 m textile cord.

Dimensions Ø: 12 cm

Use Pendants

Light E27 / E26 - max 15 W LED

Designer Soren Ravn Christensen



Silvia Create | extra leaves

Item no. ○ White 4064

 Materials Watercolour paper

 Dimensions Ø: 34 x H: 27 cm

 Use For Silvia Create lamp shade

Designer UIMAGE Design Team



Idea LED | 6W

Item no. 4026

 Materials Glass

 Dimensions Ø: 6 cm

Designer UIMAGE Design Team



Idea LED | 6W

Item no. 4033

 Materials Glass

 Dimensions Ø: 8 cm

Designer UIMAGE Design Team



Idea LED | 3W

Item no. 4034

 Materials Glass

 Dimensions Ø: 12.5 cm

Designer UIMAGE Design Team



Idea LED | 2W

Item no. 4039

 Materials Glass

 Dimensions Ø: 4.5 cm

Designer UIMAGE Design Team



Idea LED | 13W

Item no. 4136

 Materials Glass

 Dimensions Ø: 7 cm

Designer UIMAGE Design Team

INDEX



See more page 73

∞ UMAGE	Acorn black polished steel
#	Item no. 2081
⊕ ⊖	ø 14 cm / 5.5" h 16 cm / 6.3"
M	Silicone & Glass
💡	MAX 15 W LED/ E26 / E27
Designed by Jacob Rudbeck Copenhagen - Denmark	



See more page 73

∞ UMAGE	Acorn black polished brass
#	Item no. 2082
⊕ ⊖	ø 14 cm / 5.5" h 16 cm / 6.3"
M	Silicone & Glass
💡	MAX 15 W LED/ E26 / E27
Designed by Jacob Rudbeck Copenhagen - Denmark	



See more page 73

∞ UMAGE	Acorn black polished copper
#	Item no. 2083
⊕ ⊖	ø 14 cm / 5.5" h 16 cm / 6.3"
M	Silicone & Glass
💡	MAX 15 W LED/ E26 / E27
Designed by Jacob Rudbeck Copenhagen - Denmark	



See more page 73

∞ UMAGE	Acorn white polished steel
#	Item no. 2104
⊕ ⊖	ø 14 cm / 5.5" h 16 cm / 6.3"
M	Silicone & Glass
💡	MAX 15 W LED/ E26 / E27
Designed by Jacob Rudbeck Copenhagen - Denmark	



See more page 73

∞ UMAGE	Acorn white polished brass
#	Item no. 2105
⊕ ⊖	ø 14 cm / 5.5" h 16 cm / 6.3"
M	Silicone & Glass
💡	MAX 15 W LED/ E26 / E27
Designed by Jacob Rudbeck Copenhagen - Denmark	



See more page 73

∞ UMAGE	Acorn white polished copper
#	Item no. 2106
⊕ ⊖	ø 14 cm / 5.5" h 16 cm / 6.3"
M	Silicone & Glass
💡	MAX 15 W LED/ E26 / E27
Designed by Jacob Rudbeck Copenhagen - Denmark	



See more page 17

	Aluvia medium pearl white
#	Item no. 2127
	ø 59 cm / 23.3" h 48 cm / 18.9"
	Aluminum, polypropylene and PC
	MAX 15 W LED E27 / E26
Designed by UIMAGE Design Team Copenhagen - Denmark	



See more page 17

	Aluvia medium anthracite grey
#	Item no. 2129
	ø 59 cm / 23.3" h 48 cm / 18.9"
	Aluminum, polypropylene and PC
	MAX 15 W LED E27 / E26
Designed by UIMAGE Design Team Copenhagen - Denmark	



See more page 17

	Aluvia medium forest green
#	Item no. 2131
	ø 59 cm / 23.3" h 48 cm / 18.9"
	Aluminum, polypropylene and PC
	MAX 15 W LED E27 / E26
Designed by UIMAGE Design Team Copenhagen - Denmark	



See more page 17

	Aluvia medium petrol blue
#	Item no. 2133
	ø 59 cm / 23.3" h 48 cm / 18.9"
	Aluminum, polypropylene and PC
	MAX 15 W LED E27 / E26
Designed by UIMAGE Design Team Copenhagen - Denmark	



See more page 17

	Aluvia medium ruby red
#	Item no. 2135
	ø 59 cm / 23.3" h 48 cm / 18.9"
	Aluminum, polypropylene and PC
	MAX 15 W LED E27 / E26
Designed by UIMAGE Design Team Copenhagen - Denmark	



See more page 17

	Aluvia medium saffron yellow
#	Item no. 2137
	ø 59 cm / 23.3" h 48 cm / 18.9"
	Aluminum, polypropylene and PC
	MAX 15 W LED E27 / E26
Designed by UIMAGE Design Team Copenhagen - Denmark	



See more page 17

	Aluvia mini pearl white
#	Item no. 2128
	ø 40 cm / 15.7" h 30 cm / 11.8"
	Aluminum, polypropylene and PC
	MAX 15 W LED E27 / E26
	Floor and Pendant
Designed by UIMAGE Design Team Copenhagen - Denmark	



See more page 17

	Aluvia mini anthracite grey
#	Item no. 2130
	ø 40 cm / 15.7" h 30 cm / 11.8"
	Aluminum, polypropylene and PC
	MAX 15 W LED E27 / E26
	Floor and Pendant
Designed by UIMAGE Design Team Copenhagen - Denmark	



See more page 17

	Aluvia mini forest green
#	Item no. 2132
	ø 40 cm / 15.7" h 30 cm / 11.8"
	Aluminum, polypropylene and PC
	MAX 15 W LED E27 / E26
	Floor and Pendant
Designed by UIMAGE Design Team Copenhagen - Denmark	



See more page 17

	Aluvia mini petrol blue
#	Item no. 2134
	ø 40 cm / 15.7" h 30 cm / 11.8"
	Aluminum, polypropylene and PC
	MAX 15 W LED E27 / E26
	Floor and Pendant
Designed by UIMAGE Design Team Copenhagen - Denmark	



See more page 17

	Aluvia mini ruby red
#	Item no. 2136
	ø 40 cm / 15.7" h 30 cm / 11.8"
	Aluminum, polypropylene and PC
	MAX 15 W LED E27 / E26
	Floor and Pendant
Designed by UIMAGE Design Team Copenhagen - Denmark	



See more page 17

	Aluvia mini saffron yellow
#	Item no. 2138
	ø 40 cm / 15.7" h 30 cm / 11.8"
	Aluminum, polypropylene and PC
	MAX 15 W LED E27 / E26
	Floor and Pendant
Designed by UIMAGE Design Team Copenhagen - Denmark	



See more page 97

UMAGE	Alva medium white
#	Item no. 2102
⊕	ø 24.5 cm / 9.6" h 42 cm / 16.5"
M	Polypropylene & Polycarbonate
💡	MAX 15 W LED/MED - E27 / E26 (May use max 100 W CFL or LED)
Designed by Lorenzo Radaelli Copenhagen - Denmark	



See more page 23

UMAGE	Asteria pearl white
#	Item no. 2151
⊕	ø 43 cm / 16.9" h 4 cm / 1.6" / 5.6"
M	Steel, aluminum and PMMA Includes 2 m. black textile cord
💡	LED panel built-in. Dimmable with: 0-10V or Resistor or PWM Dimmers 3000 K - 1500 lm - 80 ra Energy used 22 watt
ETL	ETL certified
Designed by Soren Ravn Christensen Copenhagen - Denmark	



See more page 23

UMAGE	Asteria anthracite grey
#	Item no. 2152
⊕	ø 43 cm / 16.9" h 4 cm / 1.6" / 5.6"
M	Steel, aluminum and PMMA Includes 2 m. black textile cord
💡	LED panel built-in. Dimmable with: 0-10V or Resistor or PWM Dimmers 3000 K - 1500 lm - 80 ra Energy used 22 watt
ETL	ETL certified
Designed by Soren Ravn Christensen Copenhagen - Denmark	



See more page 23

UMAGE	Asteria ruby red
#	Item no. 2155
⊕	ø 43 cm / 16.9" h 4 cm / 1.6" / 5.6"
M	Steel, aluminum and PMMA Includes 2 m. black textile cord
💡	LED panel built-in. Dimmable with: 0-10V or Resistor or PWM Dimmers 3000 K - 1500 lm - 80 ra Energy used 22 watt
ETL	ETL certified
Designed by Soren Ravn Christensen Copenhagen - Denmark	



See more page 91

UMAGE	Carmina medium white
#	Item no. 2056
⊕	ø 48 cm / 18.9" h 36 cm / 17.2"
M	Polypropylene & Polycarbonate
💡	MAX 15 W LED/MED - E27 / E26 (May use max 100 W CFL or LED)
🔌	Floor and Pendant
Designed by Soren Ravn Christensen and Anders Klem - Copenhagen - Denmark	

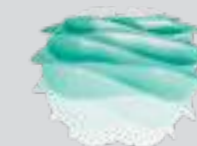

See more page 91

UMAGE	Carmina mini turquoise
#	Item no. 2059
⊕	ø 32 cm / 12.6" h 22 cm / 8.6"
M	Polypropylene & Polycarbonate
💡	MAX 15 W LED/MED - E27 / E26 (May use max 100 W CFL or LED)
🔌	Floor and Pendant
Designed by Soren Ravn Christensen and Anders Klem - Copenhagen - Denmark	



See more page 97

UMAGE	Alva mini white
#	Item no. 2103
⊕	ø 20.5 cm / 8" h 35 cm / 13.7"
M	Polypropylene & Polycarbonate
💡	MAX 15 W LED/MED - E27 / E26 (May use max 100 W CFL or LED)
Designed by Lorenzo Radaelli Copenhagen - Denmark	



See more page 23

UMAGE	Asteria forest green
#	Item no. 2153
⊕	ø 43 cm / 16.9" h 4 cm / 1.6" / 5.6"
M	Steel, aluminum and PMMA Includes 2 m. black textile cord
💡	LED panel built-in. Dimmable with: 0-10V or Resistor or PWM Dimmers 3000 K - 1500 lm - 80 ra Energy used 22 watt
ETL	ETL certified
Designed by Soren Ravn Christensen Copenhagen - Denmark	



See more page 23

UMAGE	Asteria petrol blue
#	Item no. 2154
⊕	ø 43 cm / 16.9" h 4 cm / 1.6" / 5.6"
M	Steel, aluminum and PMMA Includes 2 m. black textile cord
💡	LED panel built-in. Dimmable with: 0-10V or Resistor or PWM Dimmers 3000 K - 1500 lm - 80 ra Energy used 22 watt
ETL	ETL certified
Designed by Soren Ravn Christensen Copenhagen - Denmark	



See more page 23

UMAGE	Asteria saffron yellow
#	Item no. 2156
⊕	ø 43 cm / 16.9" h 4 cm / 1.6" / 5.6"
M	Steel, aluminum and PMMA Includes 2 m. black textile cord
💡	LED panel built-in. Dimmable with: 0-10V or Resistor or PWM Dimmers 3000 K - 1500 lm - 80 ra Energy used 22 watt
ETL	ETL certified
Designed by Soren Ravn Christensen Copenhagen - Denmark	



See more page 91

UMAGE	Carmina mini white
#	Item no. 2057
⊕	ø 32 cm / 12.6" h 22 cm / 8.6"
M	Polypropylene & Polycarbonate
💡	MAX 15 W LED/MED - E27 / E26 (May use max 100 W CFL or LED)
🔌	Floor and Pendant
Designed by Soren Ravn Christensen and Anders Klem - Copenhagen - Denmark	



See more page 91

UMAGE	Carmina mini misty grey
#	Item no. 2079
⊕	ø 32 cm / 12.6" h 22 cm / 8.6"
M	Polypropylene & Polycarbonate
💡	MAX 15 W LED/MED - E27 / E26 (May use max 100 W CFL or LED)
🔌	Floor and Pendant
Designed by Soren Ravn Christensen and Anders Klem - Copenhagen - Denmark	



See more page 91

UMAGE	Carmina mini azure
#	Item no. 2061
⊕	ø 32 cm / 12.6" h 22 cm / 8.6"
M	Polypropylene & Polycarbonate
💡	MAX 15 W LED/MED - E27 / E26 (May use max 100 W CFL or LED)
🔌	Floor and Pendant
Designed by Soren Ravn Christensen and Anders Klem - Copenhagen - Denmark	



See more page 91

UMAGE	Carmina mini sahara
#	Item no. 2063
⊕	ø 32 cm / 12.6" h 22 cm / 8.6"
M	Polypropylene & Polycarbonate
💡	MAX 15 W LED/MED - E27 / E26 (May use max 100 W CFL or LED)
🔌	Floor and Pendant
Designed by Soren Ravn Christensen and Anders Klem - Copenhagen - Denmark	



See more page 61

UMAGE	Clava brushed copper
#	Item no. 2111
⊕	ø 21.5 cm / 8.5" h 33 cm / 13"
M	Aluminum
💡	MAX 15 W LED/MED - E27 / E26 (May use max 100 W CFL or LED)
Designed by Soren Ravn Christensen Copenhagen - Denmark	



See more page 61

UMAGE	Clava polished steel
#	Item no. 2110
⊕	ø 21.5 cm / 8.5" h 33 cm / 13"
M	Aluminum
💡	MAX 15 W LED/MED - E27 / E26 (May use max 100 W CFL or LED)
Designed by Soren Ravn Christensen Copenhagen - Denmark	



See more page 61

UMAGE	Clava matte white
#	Item no. 2051
⊕	ø 21.5 cm / 8.5" h 33 cm / 13"
M	Aluminum
💡	MAX 15 W LED/MED - E27 / E26 (May use max 100 W CFL or LED)
Designed by Soren Ravn Christensen Copenhagen - Denmark	



See more page 61

UMAGE	Clava brushed brass
#	Item no. 2112
⊕	ø 21.5 cm / 8.5" h 33 cm / 13"
M	Aluminum
💡	MAX 15 W LED/MED - E27 / E26 (May use max 100 W CFL or LED)
Designed by Soren Ravn Christensen Copenhagen - Denmark	



See more page 91

UMAGE	Carmina mini baby rose
#	Item no. 2080
⊕	ø 32 cm / 12.6" h 22 cm / 8.6"
M	Polypropylene & Polycarbonate
💡	MAX 15 W LED/MED - E27 / E26 (May use max 100 W CFL or LED)
🔌	Floor and Pendant
Designed by Soren Ravn Christensen and Anders Klem - Copenhagen - Denmark	



See more page 5

UMAGE	Chimes dark oak
#	Item no. 2167
⊕	ø 3.4 cm / 1.3" h 22 cm / 8.7"
M	Oak Includes 3m black cord, metal canopy
💡	LED spot built-in. 3000 K - 220 lm - >80 ra
Designed by Asger Risborg Jacobsen Copenhagen - Denmark	



See more page 5

UMAGE	Chimes oak
#	Item no. 2165
⊕	ø 3.4 cm / 1.3" h 22 cm / 8.7"
M	Oak Includes 3m black cord, metal canopy
💡	LED panel spot-in. 3000 K - 220 lm - >80 ra
Designed by Asger Risborg Jacobsen Copenhagen - Denmark	



See more page 6

UMAGE	Clava Dine polished steel
#	Item no. 2097
⊕	ø 43 cm / 17" h 28 cm / 11"
M	Aluminum
💡	MAX 15 W LED/MED - E27 / E26 (May use max 100 W CFL or LED)
Designed by Soren Ravn Christensen Copenhagen - Denmark	



See more page 66

UMAGE	Clava Dine brushed copper
#	Item no. 2098
⊕	ø 43 cm / 17" h 28 cm / 11"
M	Aluminum
💡	MAX 15 W LED/MED - E27 / E26 (May use max 100 W CFL or LED)
Designed by Soren Ravn Christensen Copenhagen - Denmark	



See more page 66

UMAGE	Clava Dine matte white
#	Item no. 2076
⊕	ø 43 cm / 17" h 28 cm / 11"
M	Aluminum
💡	MAX 15 W LED/MED - E27 / E26 (May use max 100 W CFL or LED)
Designed by Soren Ravn Christensen Copenhagen - Denmark	



See more page 66

	Clava Dine brushed brass
#	Item no. 2099
	ø 43 cm / 17" h 28 cm / 11"
	Aluminum
	MAX 15 W LED/MED - E27 / E26 (May use max 100 W CFL or LED)
Designed by Soren Ravn Christensen Copenhagen - Denmark	



See more page 55

	Conia medium white
#	Item no. 2017
	ø 35 cm / 13.8" h 49 cm / 19.3"
	Polypropylene & Polycarbonate
	MAX 15 W LED/MED - E27 / E26 (May use max 100 W CFL or LED)
	Floor and Pendant
Designed by Soren Ravn Christensen Copenhagen - Denmark	



See more page 55

	Conia medium copper
#	Item no. 2032
	ø 35 cm / 13.8" h 49 cm / 19.3"
	Polypropylene & Polycarbonate
	MAX 15 W LED/MED - E27 / E26 (May use max 100 W CFL or LED)
	Floor and Pendant
Designed by Soren Ravn Christensen Copenhagen - Denmark	



See more page 55

	Conia medium brushed brass
#	Item no. 2095
	ø 35 cm / 13.8" h 49 cm / 19.3"
	Polypropylene & Polycarbonate
	MAX 15 W LED/MED - E27 / E26 (May use max 100 W CFL or LED)
	Floor and Pendant
Designed by Soren Ravn Christensen Copenhagen - Denmark	



See more page 103

	Cuna we white
#	Item no. 2034
	ø 38 cm / 15" h 16 cm / 6.3"
	Steel & acrylic
	MAX 15 W LED/MED - E27 / E26 (May use max 100 W CFL or LED)
Designed by UIMAGE Design Team Copenhagen - Denmark	



See more page 30

	Eos micro white
#	Item no. 2091
	ø 22 cm / 8.7" h 16 cm / 6.3"
	Goose feathers , fabric & steel
	MAX 15 W LED/MED - E27 / E26 (May use max 100 W CFL or LED)
	Approx. 500 feathers
	Floor and Pendant
	All fixtures are UL/cUL approved and fire resistant
Designed by Soren Ravn Christensen Copenhagen - Denmark	



See more page 55

	Conia mini white
#	Item no. 2019
	ø 30 cm / 11.8" h 36 cm / 14.2"
	Polypropylene & Polycarbonate
	MAX 15 W LED/MED - E27 / E26 (May use max 100 W CFL or LED)
	Floor and Pendant
Designed by Soren Ravn Christensen Copenhagen - Denmark	



See more page 55

	Conia mini copper
#	Item no. 2033
	ø 30 cm / 11.8" h 36 cm / 14.2"
	Polypropylene & Polycarbonate
	MAX 15 W LED/MED - E27 / E26 (May use max 100 W CFL or LED)
	Floor and Pendant
Designed by Soren Ravn Christensen Copenhagen - Denmark	



See more page 55

	Conia mini brushed brass
#	Item no. 2096
	ø 30 cm / 11.8" h 36 cm / 14.2"
	Polypropylene & Polycarbonate
	MAX 15 W LED/MED - E27 / E26 (May use max 100 W CFL or LED)
	Floor and Pendant
Designed by Soren Ravn Christensen Copenhagen - Denmark	



See more page 103

	Cuna matte black
#	Item no. 2035
	ø 38 cm / 15" h 16 cm / 6.3"
	Steel & acrylic
	MAX 15 W LED/MED - E27 / E26 (May use max 100 W CFL or LED)
Designed by UIMAGE Design Team Copenhagen - Denmark	



See more page 103

	Cuna mint green
#	Item no. 2036
	ø 38 cm / 15" h 16 cm / 6.3"
	Steel & acrylic
	MAX 15 W LED/MED - E27 / E26 (May use max 100 W CFL or LED)
Designed by UIMAGE Design Team Copenhagen - Denmark	



See more page 30

	Eos mini white
#	Item no. 2011
	ø 35 cm / 13.8" h 20 cm / 7.9"
	Goose feathers & paper
	MAX 15 W LED/MED - E27 / E26 (May use max 100 W CFL or LED)
	Approx. 900 feathers
	Floor and Pendant
	All fixtures are UL/cUL approved and fire resistant
Designed by Soren Ravn Christensen Copenhagen - Denmark	



See more page 34

	Eos medium white
#	Item no. 2010
	ø 45 cm / 17.7" h 30 cm / 11.8"
	Goose feathers & paper
	MAX 15 W LED/MED - E27 / E26 (May use max 100 W CFL or LED)
	Approx. 1.800 feathers
	Floor and Pendant
	All fixtures are UL/cUL approved and fire resistant
Designed by Soren Ravn Christensen Copenhagen - Denmark	



See more page 34

	Eos large white
#	Item no. 2042
	ø 65 cm / 25.6" h 40 cm / 15.7"
	Goose feathers & paper
	MAX 15 W LED/MED - E27 / E26 (May use max 100 W CFL or LED)
	Approx. 4.500 feathers
	Floor and Pendant
	All fixtures are UL/cUL approved and fire resistant
Designed by Soren Ravn Christensen Copenhagen - Denmark	



See more page 30

	Eos micro light grey
#	Item no. 2123
	ø 22 cm / 8.7" h 16 cm / 6.3"
	Goose feathers , fabric & steel
	MAX 15 W LED/MED - E27 / E26 (May use max 100 W CFL or LED)
	Approx. 500 feathers
	Floor and Pendant
	All fixtures are UL/cUL approved and fire resistant
Designed by Soren Ravn Christensen Copenhagen - Denmark	



See more page 30

	Eos mini light grey
#	Item no. 2124
	ø 35 cm / 13.8" h 20 cm / 7.9"
	Goose feathers, paper and steel
	MAX 15 W LED - E26
	Approx. 900 feathers
	Floor and Pendant
	All fixtures are UL/cUL approved and fire resistant
Designed by Soren Ravn Christensen Copenhagen - Denmark	

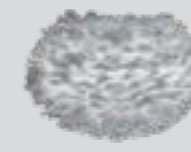

See more page 34

	Eos medium light grey
#	Item no. 2085
	ø 45 cm / 17.7" h 30 cm / 11.8"
	Goose feathers & paper
	MAX 15 W LED/MED - E27 / E26 (May use max 100 W CFL or LED)
	Approx. 1.800 feathers
	Floor and Pendant
	All fixtures are UL/cUL approved and fire resistant
Designed by Soren Ravn Christensen Copenhagen - Denmark	



See more page 30

	Eos micro light brown
#	Item no. 2125
	ø 22 cm / 8.7" h 16 cm / 6.3"
	Goose feathers & paper
	MAX 15 W LED/MED - E27 / E26 (May use max 100 W CFL or LED)
	Approx. 500 feathers
	Floor and Pendant
	All fixtures are UL/cUL approved and fire resistant
Designed by Soren Ravn Christensen Copenhagen - Denmark	



See more page 38

	Eos x-large white
#	Item no. 2012
	ø 75 cm / 29.5" h 45 cm / 17.7"
	Goose feathers & paper
	MAX 15 W LED/MED - E27 / E26 (May use max 100 W CFL or LED)
	Approx. 6.000 feathers
	All fixtures are UL/cUL approved and fire resistant
Designed by Soren Ravn Christensen Copenhagen - Denmark	



See more page 38

	Eos xx-large white
#	Item no. 2041
	ø 110 cm / 43.3" h 70 cm / 27.6"
	Goose feathers & paper
	MAX 15 W LED/MED - E27 / E26 (May use max 100 W CFL or LED)
	Approx. 13.500 feathers
	All fixtures are UL/cUL approved and fire resistant
Designed by Soren Ravn Christensen Copenhagen - Denmark	

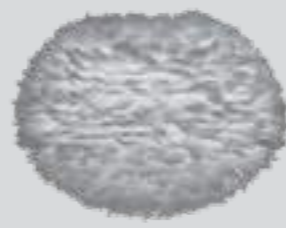

See more page 34

	Eos large light grey
#	Item no. 2090
	ø 65 cm / 25.6" h 40 cm / 15.7"
	Goose feathers & paper
	MAX 15 W LED/MED - E27 / E26 (May use max 100 W CFL or LED)
	Approx. 4.500 feathers
	Floor and Pendant
	All fixtures are UL/cUL approved and fire resistant
Designed by Soren Ravn Christensen Copenhagen - Denmark	

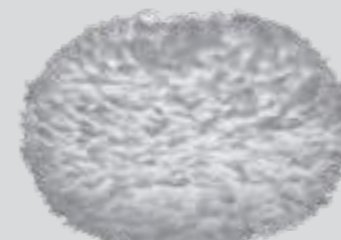

See more page 38

	Eos x-large light grey
#	Item no. 2090
	ø 75 cm / 29.5" h 45 cm / 17.7"
	Goose feathers & paper
	MAX 15 W LED/MED - E27 / E26 (May use max 100 W CFL or LED)
	Approx. 6.000 feathers
	All fixtures are UL/cUL approved and fire resistant
Designed by Soren Ravn Christensen Copenhagen - Denmark	



See more page 30

	Eos mini light brown
#	Item no. 2126
	ø 35 cm / 13.8" h 20 cm / 7.9"
	Goose feathers & paper
	MAX 15 W LED/MED - E27 / E26 (May use max 100 W CFL or LED)
	Approx. 900 feathers
	Floor and Pendant
	All fixtures are UL/cUL approved and fire resistant
Designed by Soren Ravn Christensen Copenhagen - Denmark	



See more page 34

	Eos medium light brown
#	Item no. 2066
	ø 45 cm / 17.7" h 30 cm / 11.8"
	Goose feathers & paper
	MAX 15 W LED/MED - E27 / E26 (May use max 100 W CFL or LED)
	Approx. 1.800 feathers
	Floor and Pendant
	All fixtures are UL/cUL approved and fire resistant
Designed by Soren Ravn Christensen Copenhagen - Denmark	



See more page 34

UMAGE	Eos large light brown
#	Item no. 2089
⊕	ø 65 cm / 25.6" h 40 cm / 15.7"
M	Goose feathers & paper
💡	MAX 15 W LED/MED - E27 / E26 (May use max 100 W CFL or LED)
🍃	Approx. 4.500 feathers
🏠	Floor and Pendant
UL	All fixtures are UL/cUL approved and fire resistant
Designed by Soren Ravn Christensen Copenhagen - Denmark	



See more page 43

UMAGE	Eos Up white
#	Item no. 2150
⊕	ø 40 cm / 15.7" h 15 cm / 5.9"
M	Goose feathers, fabric and steel
💡	MAX 15 W LED E27 / E26
🏠	Ceiling and wall in one
UL	All fixtures are UL/cUL approved and fire resistant
Designed by Soren Ravn Christensen Copenhagen - Denmark	



See more page 11

UMAGE	Ribbon mini white
#	Item no. 2164
⊕	ø 19 cm / 7.5" h 33 cm / 13"
M	Polypropylene, POM
💡	MAX 15 W LED/MED - E27 / E26 (May use max 100 W CFL or LED)
Designed by Lorenzo Radaelli Copenhagen - Denmark	



See more page 11

UMAGE	Ribbon medium white
#	Item no. 2163
⊕	ø 28 cm / 11" h 49.5 cm / 19.5"
M	Polypropylene, POM
💡	MAX 15 W LED/MED - E27 / E26 (May use max 100 W CFL or LED)
Designed by Lorenzo Radaelli Copenhagen - Denmark	



See more page 79

UMAGE	Shade felt
#	Item no. 2107
⊕	ø 33 cm / 12.9" h 3,3 cm / 1.2"
M	PET felt
💡	MAX 15 W LED E27 / E26
🏠	Floor and pendant in one
Designed by Soren Ravn Christensen Copenhagen - Denmark	



See more page 85

UMAGE	Sine felt grey
#	Item no. 2084
⊕	ø 57 cm / 22.4" h 18 cm / 7"
M	PET felt and polypropylene
💡	MAX 15 W LED E27 / E26
Designed by Miklos Leits Copenhagen - Denmark	



See more page 38

UMAGE	Eos x-large light brown
#	Item no. 2067
⊕	ø 75 cm / 29.5" h 45 cm / 17.7"
M	Goose feathers & paper
💡	MAX 15 W LED/MED - E27 / E26 (May use max 100 W CFL or LED)
🍃	Approx. 6.000 feathers
UL	All fixtures are UL/cUL approved and fire resistant
Designed by Soren Ravn Christensen Copenhagen - Denmark	

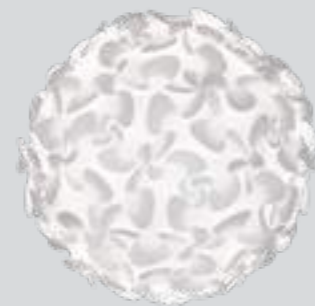

See more page 109

UMAGE	Lora x-large white
#	Item no. 2065
⊕	ø 75 cm / 29.5" h 75 cm / 29.5"
M	Polypropylene
💡	MAX 15 W LED/MED - E27 / E26 (May use max 100 W CFL or LED)
Designed by Lorenzo Radaelli Copenhagen - Denmark	

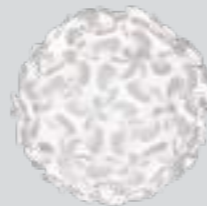

See more page 109

UMAGE	Lora medium white
#	Item no. 2064
⊕	ø 45 cm / 17.7" h 45 cm / 17.7"
M	Polypropylene
💡	MAX 15 W LED/MED - E27 / E26 (May use max 100 W CFL or LED)
Designed by Lorenzo Radaelli Copenhagen - Denmark	



See more page 121

UMAGE	Ripples cusp white
#	Item no. 2043
⊕	ø 15 cm / 5.9" h 21 cm / 8.3"
M	Silicone & PC
💡	MAX 15 W LED/ E26 / E27
Designed by Soren ravn Christensen Copenhagen - Denmark	



See more page 121

UMAGE	Ripples slope white
#	Item no. 2044
⊕	ø 15 cm / 5.9" h 19 cm / 7.5"
M	Silicone & PC
💡	MAX 15 W LED/ E26 / E27
Designed by Soren ravn Christensen Copenhagen - Denmark	



See more page 121

UMAGE	Ripples curve white
#	Item no. 2045
⊕	ø 15 cm / 5.9" h 20 cm / 7.8"
M	Silicone & PC
💡	MAX 15 W LED/ E26 / E27
Designed by Soren ravn Christensen Copenhagen - Denmark	



See more page 49

	Silvia medium white
#	Item no. 2007
	ø 45 cm / 17.7" h 45 cm / 17.7"
	Polypropylene & Polycarbonate
	MAX 15 W LED/MED - E27 / E26 (May use max 100 W CFL or LED)
	Floor and Pendant
Designed by UIMAGE Design Team Copenhagen - Denmark	



See more page 49

	Silvia medium copper
#	Item no. 2030
	ø 45 cm / 17.7" h 45 cm / 17.7"
	Polypropylene & Polycarbonate
	MAX 15 W LED/MED - E27 / E26 (May use max 100 W CFL or LED)
	Floor and Pendant
Designed by UIMAGE Design Team Copenhagen - Denmark	



See more page 49

	Silvia medium brushed steel
#	Item no. 2053
	ø 45 cm / 17.7" h 45 cm / 17.7"
	Polypropylene & Polycarbonate
	MAX 15 W LED/MED - E27 / E26 (May use max 100 W CFL or LED)
	Floor and Pendant
Designed by UIMAGE Design Team Copenhagen - Denmark	



See more page 49

	Silvia medium brushed brass
#	Item no. 2070
	ø 45 cm / 17.7" h 45 cm / 17.7"
	Polypropylene & Polycarbonate
	MAX 15 W LED/MED - E27 / E26 (May use max 100 W CFL or LED)
	Floor and Pendant
Designed by UIMAGE Design Team Copenhagen - Denmark	



See more page 115

	Silvia mini create
#	Item no. 2100
	ø 34 cm / 13.4" h 27 cm / 10.6"
	Polypropylene & watercolor paper
	MAX 15 W LED E27 / E26
	Floor and pendant in one
Designed by UIMAGE Design Team Copenhagen - Denmark	

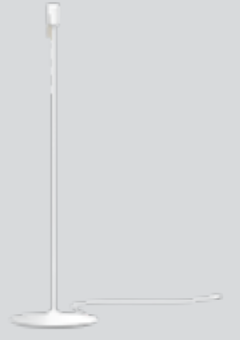

See more page 145

	Champagne white
#	Item no. 4037
	ø 38 cm / 15" h 140 cm / 55"
	Aluminum / steel / MDF / ABS
	Max 60 W - E26
	1.5 m/59.1" fabric covered cord including plug and switch
	UL/cUL certified
Designed by Anders Klem Copenhagen - Denmark	



See more page 49

	Silvia mini white
#	Item no. 2009
	ø 34 cm / 13.4" h 27 cm / 10.6"
	Polypropylene & Polycarbonate
	MAX 15 W LED/MED - E27 / E26 (May use max 100 W CFL or LED)
	Floor and Pendant
Designed by UIMAGE Design Team Copenhagen - Denmark	



See more page 49

	Silvia mini copper
#	Item no. 2031
	ø 34 cm / 13.4" h 27 cm / 10.6"
	Polypropylene & Polycarbonate
	MAX 15 W LED/MED - E27 / E26 (May use max 100 W CFL or LED)
	Floor and Pendant
Designed by UIMAGE Design Team Copenhagen - Denmark	



See more page 49

	Silvia mini brushed steel
#	Item no. 2054
	ø 34 cm / 13.4" h 27 cm / 10.6"
	Polypropylene & Polycarbonate
	MAX 15 W LED/MED - E27 / E26 (May use max 100 W CFL or LED)
	Floor and Pendant
Designed by UIMAGE Design Team Copenhagen - Denmark	



See more page 49

	Silvia mini brushed brass
#	Item no. 2071
	ø 34 cm / 13.4" h 27 cm / 10.6"
	Polypropylene & Polycarbonate
	MAX 15 W LED/MED - E27 / E26 (May use max 100 W CFL or LED)
	Floor and Pendant
Designed by UIMAGE Design Team Copenhagen - Denmark	



See more page 154

	Silvia Create extra leaves
#	Item no. 4064
	ø 34 cm / 13.4" h 27 cm / 10.6"
	Watercolor paper
	MAX 15 W LED/MED - E27 / E26 (May use max 100 W CFL or LED)
	Floor and Pendant
Designed by UIMAGE Design Team Copenhagen - Denmark	

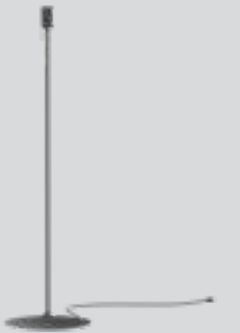

See more page 145

	Champagne black
#	Item no. 4038
	ø 38 cm / 15" h 140 cm / 55"
	Aluminum / steel / MDF / ABS
	Max 60 W - E26
	1.5 m/59.1" fabric covered cord including plug and switch
	UL/cUL certified
Designed by Anders Klem Copenhagen - Denmark	



See more page 137

UMAGE	Willow single white
#	Item no. 4110
↕	l 77.7 cm / 30.6" h 123 cm / 48.5"
M	Aluminum / steel
💡	Max 60 W - E26
🔌	1.3 m/51.2" fabric covered cord including plug and switch
UL/US	UL/cUL certified
Designed by Soren Ravn Christensen Copenhagen - Denmark	



See more page 137

UMAGE	Willow double white
#	Item no. 4130
↕	l 140 cm / 77.7 cm / 15.7" / 30.6" h 123 cm / 48.5"
M	Aluminum / steel
💡	Max 60 W - E26
🔌	1.3 m/51.2" fabric covered cord including 2 x plug and switch
UL/US	UL/cUL certified
Designed by Soren Ravn Christensen Copenhagen - Denmark	



See more page 137

UMAGE	Willow mini white
#	Item no. 4150
↕	l 29.8 cm / 11.7" h 50.1 cm / 19.7"
M	Aluminum / steel
💡	Max 60 W - E26
🔌	1.3 m/51.2" fabric covered cord including plug and switch
UL/US	UL/cUL certified
Designed by Soren Ravn Christensen Copenhagen - Denmark	



See more page 129

UMAGE	Tripod floor white
#	Item no. 4015
↕	ø 66 cm / 26" h 109 cm / 42.9"
M	Aluminum
💡	MAX 15 W LED/MED - E26 (May use max 100 W CFL or LED)
🔌	3.0 m/9' 10" fabric covered cord including plug and switch
UL/US	UL/cUL certified
Designed by Soren Ravn Christensen Copenhagen - Denmark	



See more page 129

UMAGE	Tripod table white
#	Item no. 4021
↕	ø 19 cm / 7.4" h 36 cm / 14.2"
M	Aluminum
💡	MAX 15 W LED/MED - E26 (May use max 100 W CFL or LED)
🔌	2.0 m/6' 6" fabric covered cord including plug and switch
UL/US	UL/cUL certified
Designed by Soren Ravn Christensen Copenhagen - Denmark	



See more page 129

UMAGE	Tripod base white
#	Item no. 4053
↕	ø 15.8/24 cm 6.2/ 9.4" h 18.6/12.5 cm 7.3/4.9"
M	Aluminum
💡	MAX 15 W LED/MED - E26 (May use max 100 W CFL or LED)
🔌	2.0 m/6' 6" fabric covered cord including plug and switch
UL/US	UL/cUL certified
Designed by Soren Ravn Christensen Copenhagen - Denmark	

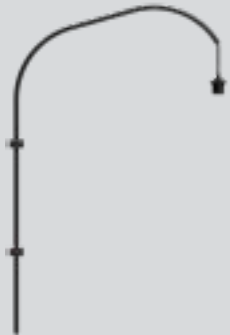

See more page 137

UMAGE	Willow single black
#	Item no. 4111
↕	l 77.7 cm / 30.6" h 123 cm / 48.5"
M	Aluminum / steel
💡	Max 60 W - E26
🔌	1.3 m/51.2" fabric covered cord including plug and switch
UL/US	UL/cUL certified
Designed by Soren Ravn Christensen Copenhagen - Denmark	



See more page 137

UMAGE	Willow double black
#	Item no. 4131
↕	l 140 cm / 77.7 cm / 15.7" / 30.6" h 123 cm / 48.5"
M	Aluminum / steel
💡	Max 60 W - E26
🔌	1.3 m/51.2" fabric covered cord including 2 x plug and switch
UL/US	UL/cUL certified
Designed by Soren Ravn Christensen Copenhagen - Denmark	



See more page 137

UMAGE	Willow mini black
#	Item no. 4151
↕	l 29.8 cm / 11.7" h 50.1 cm / 19.7"
M	Aluminum / steel
💡	Max 60 W - E26
🔌	1.3 m/51.2" fabric covered cord including plug and switch
UL/US	UL/cUL certified
Designed by Soren Ravn Christensen Copenhagen - Denmark	



See more page 129

UMAGE	Tripod floor black
#	Item no. 4016
↕	ø 66 cm / 26" h 109 cm / 42.9"
M	Aluminum
💡	MAX 15 W LED/MED - E26 (May use max 100 W CFL or LED)
🔌	3.0 m/9' 10" fabric covered cord including plug and switch
UL/US	UL/cUL certified
Designed by Soren Ravn Christensen Copenhagen - Denmark	



See more page 129

UMAGE	Tripod table black
#	Item no. 4022
↕	ø 19 cm / 7.4" h 36 cm / 14.2"
M	Aluminum
💡	MAX 15 W LED/MED - E26 (May use max 100 W CFL or LED)
🔌	2.0 m/6' 6" fabric covered cord including plug and switch
UL/US	UL/cUL certified
Designed by Soren Ravn Christensen Copenhagen - Denmark	



See more page 129

UMAGE	Tripod base black
#	Item no. 4054
↕	ø 15.8/24 cm 6.2/ 9.4" h 18.6/12.5 cm 7.3/4.9"
M	Aluminum
💡	MAX 15 W LED/MED - E26 (May use max 100 W CFL or LED)
🔌	2.0 m/6' 6" fabric covered cord including plug and switch
UL/US	UL/cUL certified
Designed by Soren Ravn Christensen Copenhagen - Denmark	



Designers



Soren Ravn Christensen
Chief Creative Developer



Anders Klem



Jacob Rudbeck

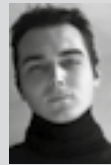

Lorenzo Radaelli



Asger Risborg Jacobsen



Miklos Leits

At UIMAGE, our designers take inspiration from the distinct nature of the Nordic landscape to create unique designs related to the way we live in an urban setting. Influenced by the design language, colours and materials found around us in Scandinavia, we create a collection that is rooted in our home but designed for everyone.

Follow us on social media for fresh news and inspiration for your own interior design ideas and much more.



@umagedesign | #umagedesign
umage.com | info@umage.com | +45 31 39 31 31

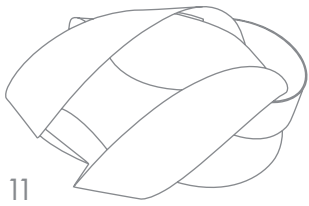

11



17

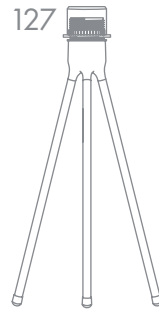

127

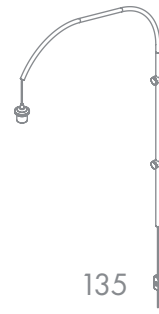

135

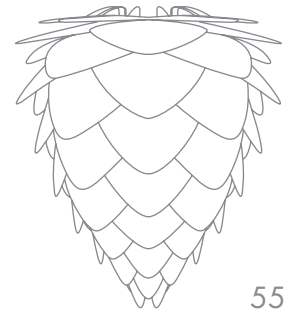

55

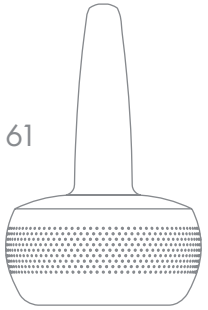

61

85

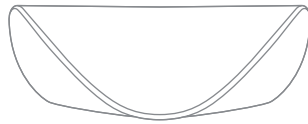

73

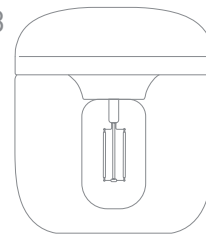

143

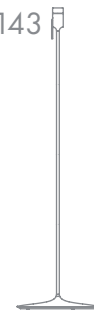

135

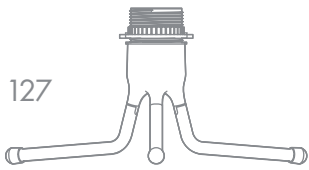
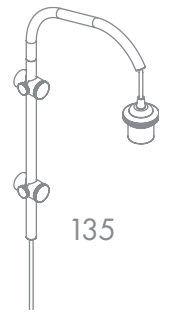

127

79



103

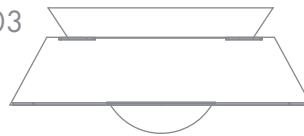

91

23

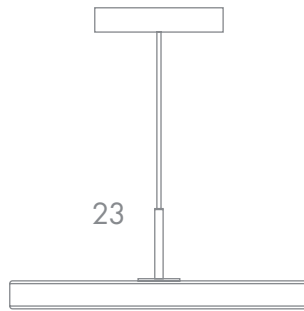

67

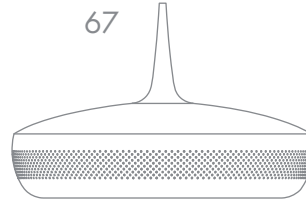

97

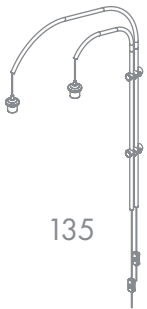
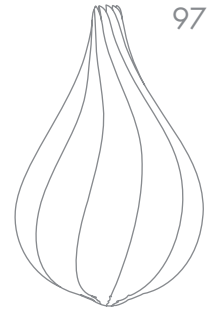

135

121

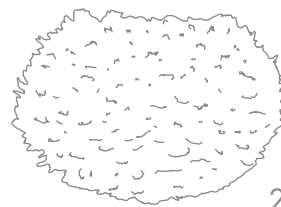
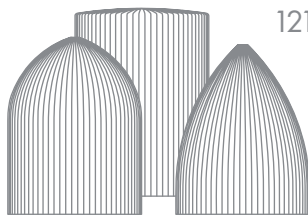

29

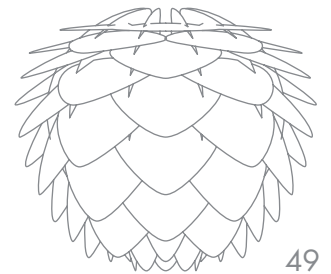

49



115

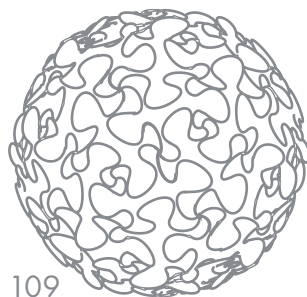

109



127



5



37



WOJNAROWSKI

tel . 32 735 0 537
biuro@wojnarowskilighting.pl

Porcelanowa 23, bud. B
40-246 Katowice

NIP: 9542793763
REGON: 380582520

WWW.WOJNAROWSKILIGHTING.PL