



WOJNAROWSKI

PREZENTUJE

VISO
LIGHT IS LIFE

BRAND
| COLLECTION







BRONZE COLLECTION 2017

CHESTNUT | BRIGGS | ALO

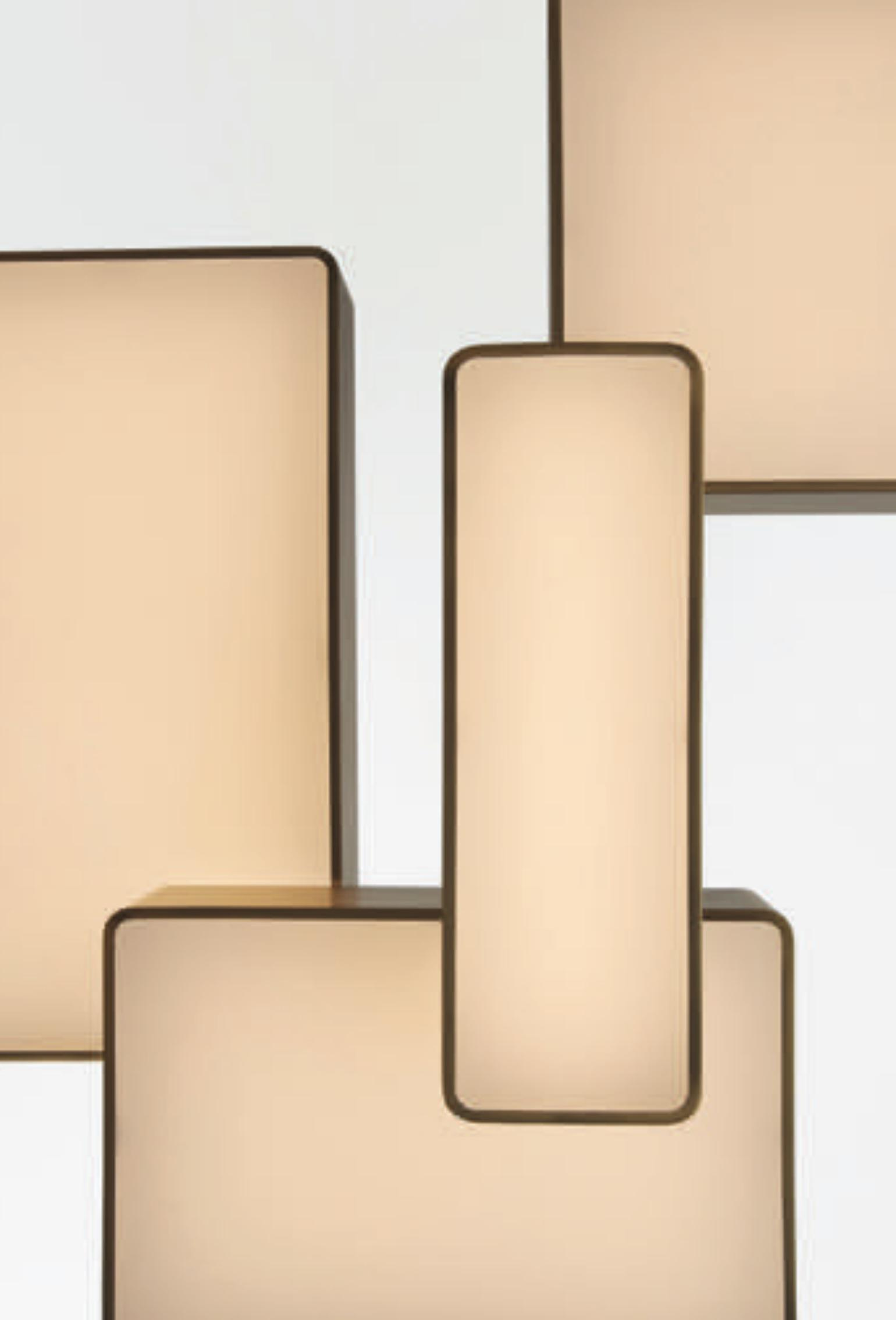

ALO

Sleek. Confident. Innovative.

- Frosted glass pendant with clear accents
- Plated metal available in multiple proprietary finishes
- Frosted glass acts as diffuser
- Available with 8"/203mm or 4"/102mm stems
- Includes silver coaxial cable cord
- Custom clusters are available
- Dimming options are available for clusters of 5 and up
- LED
- Designer
Filipe Lisboa



AVAILABLE FINISHES



SPECS

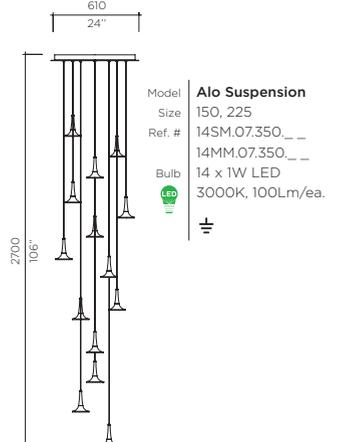
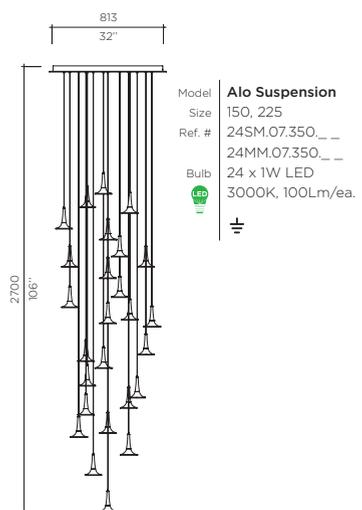
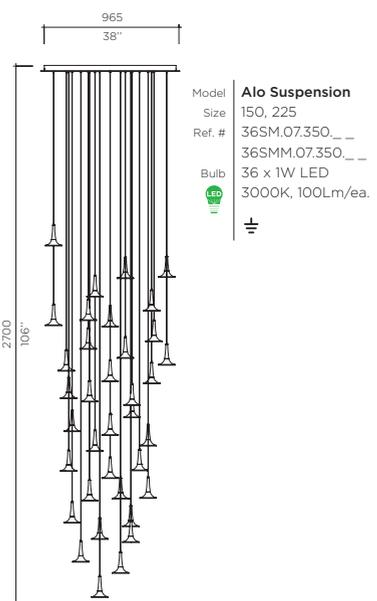
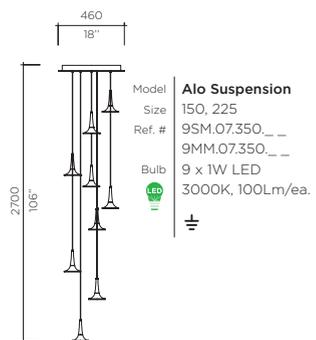
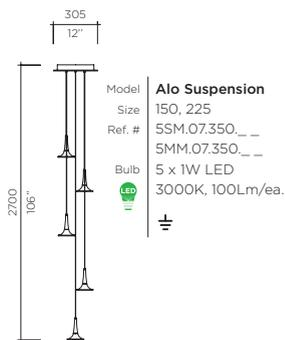
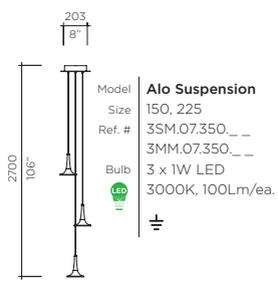
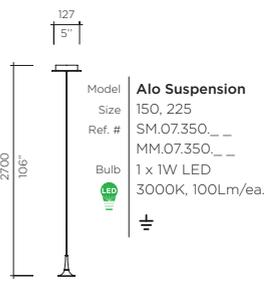



MADE WITH LOVE COLLECTION 2016





MARTINI

MARTINI

Elegant. Majestic. Chic.

- Semi-metalized polycarbonate shape
- Polished chrome metal components
- Inverted version is also available
- Includes black cloth cord
- Custom canopy is available upon request
- Custom clusters are available
- LED

— Designer
Filipe Lisboa



COLOUR OPTIONS



SPECS

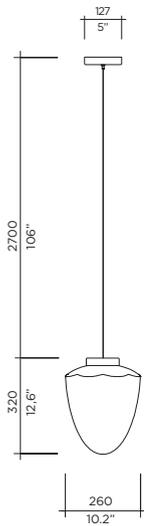

Model **Martini Suspension**
 Size 260
 Ref. # SM.07.201._ Standard
 SM.07.221._ Inverted
 Bulb 1 x 7.8W LED
 3000K, 700 Lm
 Triac/ELV/0-10V Dimming Available
 Dims from 100% - 15%

CONFIGURATIONS

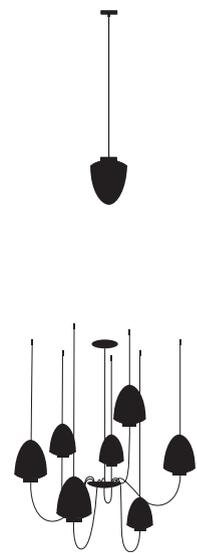





MAGGIE

MAGGIE
Custom cluster
configuration



MAGGIE
Display as
seen at the
2016 Light+
Building show
in Frankfurt
Germany



MAGGIE

Contemporary. Dynamic. Smart.

- Two-tone suspension light
- Spun steel globe with plated finish
- White opal glass insert
- Dynamic magnet attachment doubles as support cable and design accessory that changes fixture's orientation according to customer's needs
- Spun steel globe and canopy are available in various finishes
- Custom clusters are available
- Includes black cloth cord
- LED
- Designer
- VISO Design Studio



AVAILABLE FINISHES

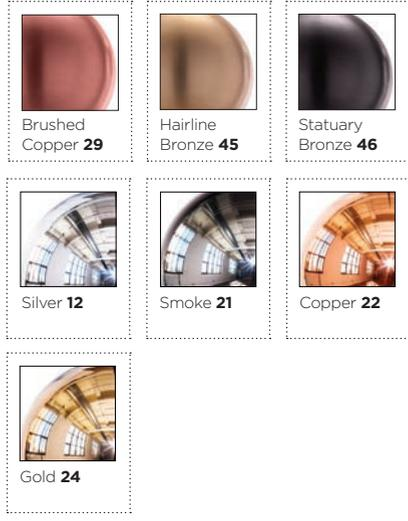

SPECS

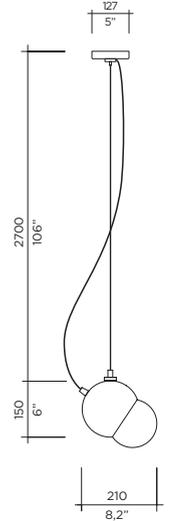

Model **The Maggie Suspension**
 Size 210
 Ref. # SM.07.301_ _
 Bulb 7W LED
 3000K, 680Lm
 Triac/ELV/0-10V Dimming Available
 Dims from 100% - 15%

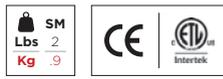





WANDERING STAR

WANDERING STAR

Luminous. Tactile. Posh.

Dual-tone globe with solid European marble top and cast glass lens with diffuser on the inside

Metal plated details in hairline bronze finish

Includes silver coaxial cable

Custom clusters are available

Custom canopies are available

LED

Designer

Filipe Lisboa



AVAILABLE FINISHES



SPECS

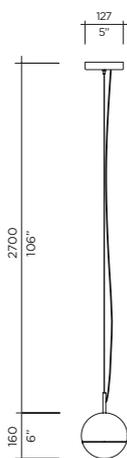
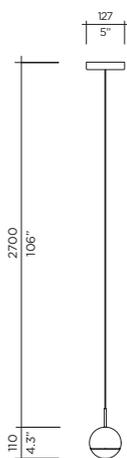

Model **Wandering Star Suspension**
 Size 110
 Ref. # SM.07.351._._
 Bulb 5.5W LED
 3000K, 440Lm
 Triac/ELV/0-10V Dimming Available
 Dims from 100% - 15%

Model **Wandering Star Suspension**
 Size 160
 Ref. # MM.07.351._._
 Bulb 12W LED
 3000K, 960Lm
 Triac/ELV/0-10V Dimming Available
 Dims from 100% - 15%

	SM	MM		
Lbs	4	11		
Kg	1.8	5		





CREMA

CREMA

Luminous. Effortless. Serene.

Semi-metalized top quality polycarbonate body

Matte white steel top

Solid glass LED diffuser

Includes white cord

Custom clusters are available

Custom canopies are available

Designer

Filipe Lisboa



AVAILABLE FINISHES



Semi-metalized Silver **12**



Semi-metalized Copper **22**



SPECS

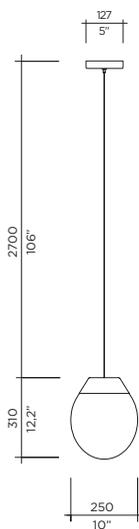

Model **Crema Suspension**
 Size **250**
 Ref. # **SM.07.770. _ _**
 Bulb **1 x 7.8W LED**
3000K, 700Lm
 Triac/ELV/0-10V Dimming Available
 Dims from 100% - 15%





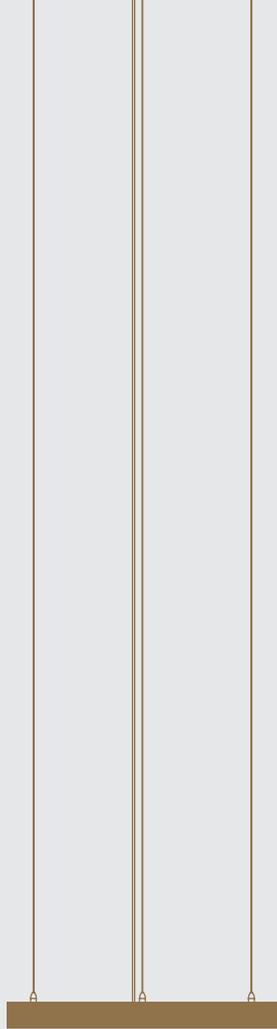

THE RING

THE ESSENTIALS COLLECTION

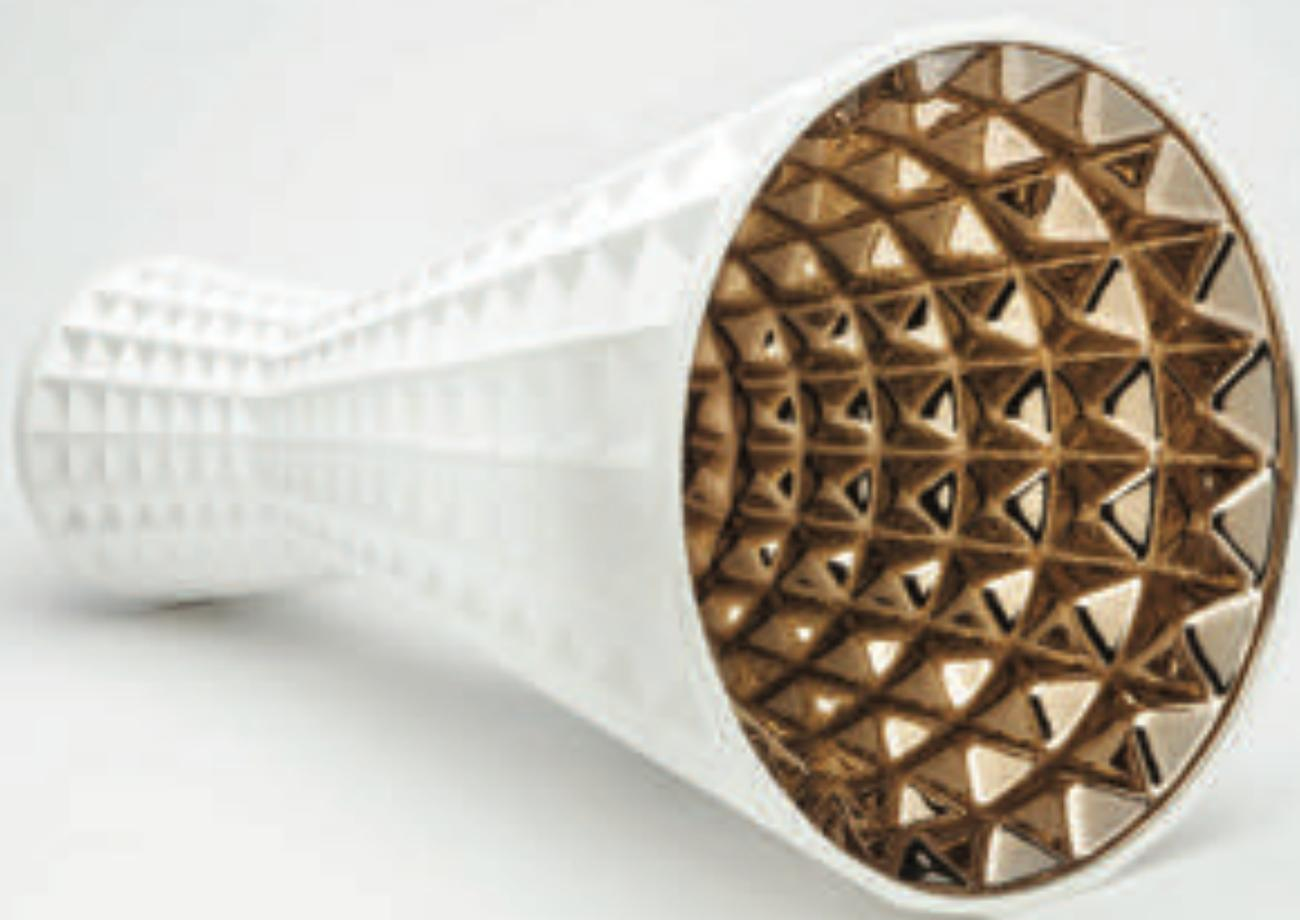

FUNKII

Unpredictable. Fortune. Play.

- High-quality ceramic body
- Metalized interior finish
- Custom drops are available
- Custom canopies are available
- LED option is available

Designer
Filipe Lisboa



METALLIC FINISHES

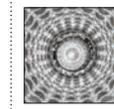

Silver 12



Copper 22

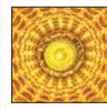

Gold 24

SPECS

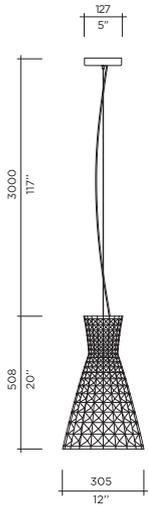

- Model **Funkii Suspension**
 Size **508**
 Ref. # **GM.07.951_**
 Bulb **E26 / E27 (120V/220V)**
1 x 100W max
 Incandescent
 **1 x 100W equivalent**



PROJECT
ALX Design Showroom



PROJECT
Audi Headquarters



H2O

Grand. Organic. Affable.

- Semi-metalized top quality polycarbonate body
- Chrome metal canopy
- Custom clusters are available
- Custom canopies are available
- LED option is available

— Designer
Filipe Lisboa



METALLIC FINISHES

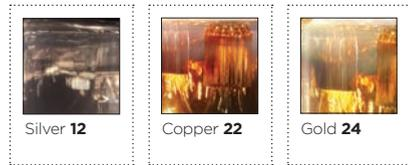

CONFIGURATIONS

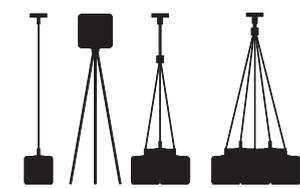

SPECS

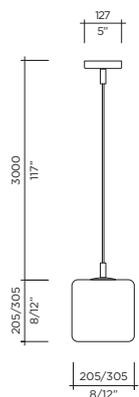

Model **H2O Suspension**
Size 205, 305
Ref. # SM.07.861___
GM.07.862___
Bulb E26 / E27 (120V/220V)
1 x 40W max
1 x 60W max
Incandescent
LED 1 x 40W equivalent
1 x 60W equivalent

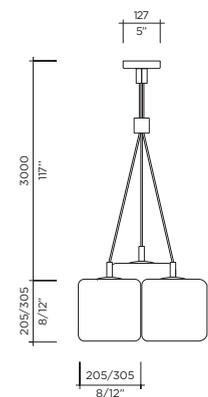

Model **H2O Suspension**
Size 205, 305
Ref. # SM.07.865___
GM.07.865___
Bulb E26 / E27 (120V/220V)
3 x 40W max
3 x 60W max
Incandescent
LED 3 x 40W equivalent
3 x 60W equivalent

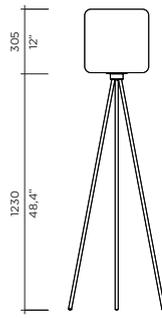
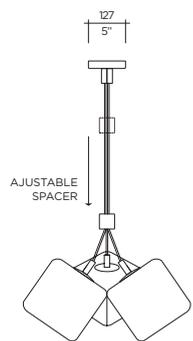

Model **H2O Floor**
Size 305
Ref. # GM.08.862___
Bulb E26 / E27 (120V/220V)
1 x 60W max
Incandescent
LED 1 x 60W equivalent

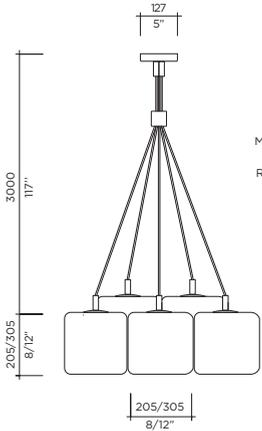

Model **H2O Suspension**
Size 205, 305
Ref. # SM.07.867___
GM.07.867___
Bulb E26 / E27 (120V/220V)
5 x 40W max
5 x 60W max
Incandescent
LED 5 x 40W equivalent
5 x 60W equivalent

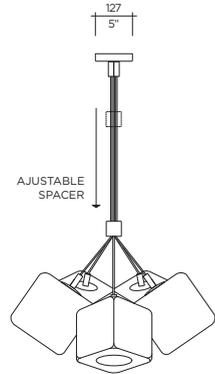

	SM	MM		
Lbs	3	5		Intermark
Kg	1.4	2.3		

GIA ROUND

Glamorous. Luxurious. Stimulating.

- Dazzling four faceted Asfour crystals
- Chrome plated frame
- Chrome metal canopy
- Custom canopies are available
- Custom designs and drops are available
- LED option is available

Designer
Filipe Lisboa



CONFIGURATIONS

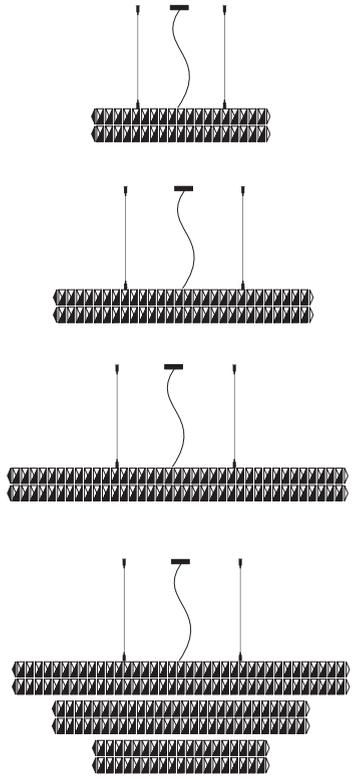

SPECS

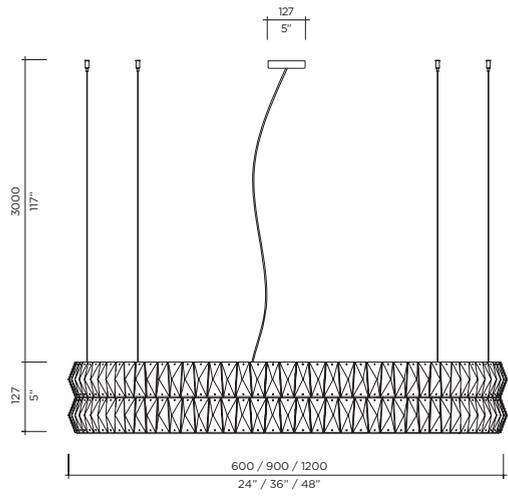

Model	Gia Round Suspension
Size	600, 900, 1200
Ref. #	SM.07.281 MM.07.281 GM.07.281
Bulb	G9 Bi-Pin Halogen (120V/220V)
	6 x 25W (600)
	10 x 25W (900)
	12 x 25W (1200)
	6 x 25W equivalent
	10 x 25W equivalent
	12 x 25W equivalent

	SM	MM	GM	CE	ETL Intertek
Lbs	35	45	58		
Kg	15.9	20.4	26.3		

GIA

Organic. Demanding. Friendly.

- Dazzling four faceted Asfour crystals
- Chrome plated frame
- Chrome metal canopy
- Custom canopies are available
- Custom designs and drops are available
- LED option is available

— Designer
Filipe Lisboa



CONFIGURATIONS

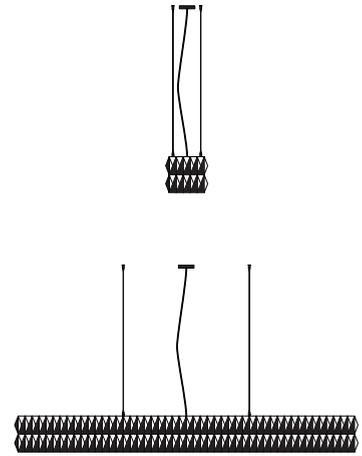

SPECS

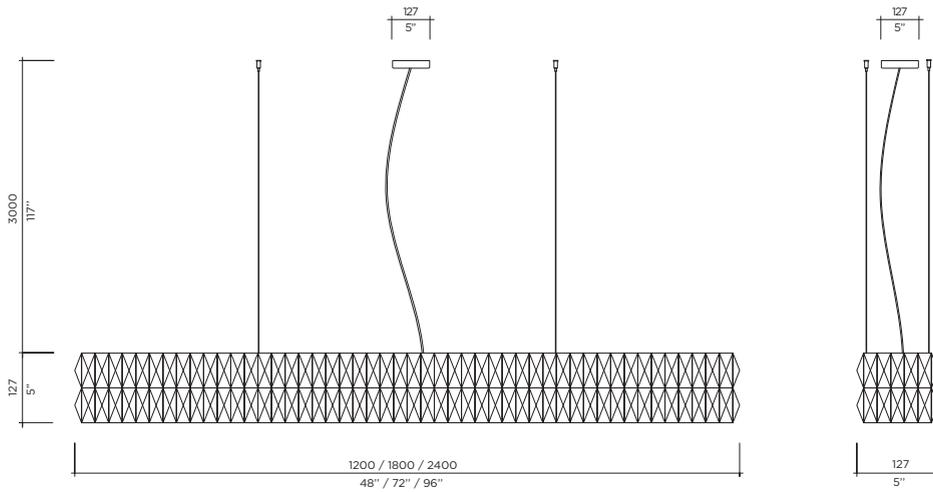

Model	Gia Suspension
Size	1200, 1800, 2400
Ref. #	SM.07.271 MM.07.271 GM.07.271
Bulb	G9 Bi-Pin Halogen (120V/220V)
	5 x 25W (1200)
	7 x 25W (1800)
	10 x 25W (2400)
	5 x 25W equivalent
	7 x 25W equivalent
	10 x 25W equivalent

	SM	MM	GM
Lbs	35	45	58
Kg	15.9	20.4	26.3



FORT KNOX

Wisdom. Duty. Trust.

- High-quality polycarbonate body for sizes SM, MM and GM
- Spun metal body for size BM with white interior
- Metalized interior and exterior finish
- Black metal canopy
- Custom canopies and drops are available
- Includes black cable
- LED option is available

Designer
Filipe Lisboa



METALLIC FINISHES



SPECS

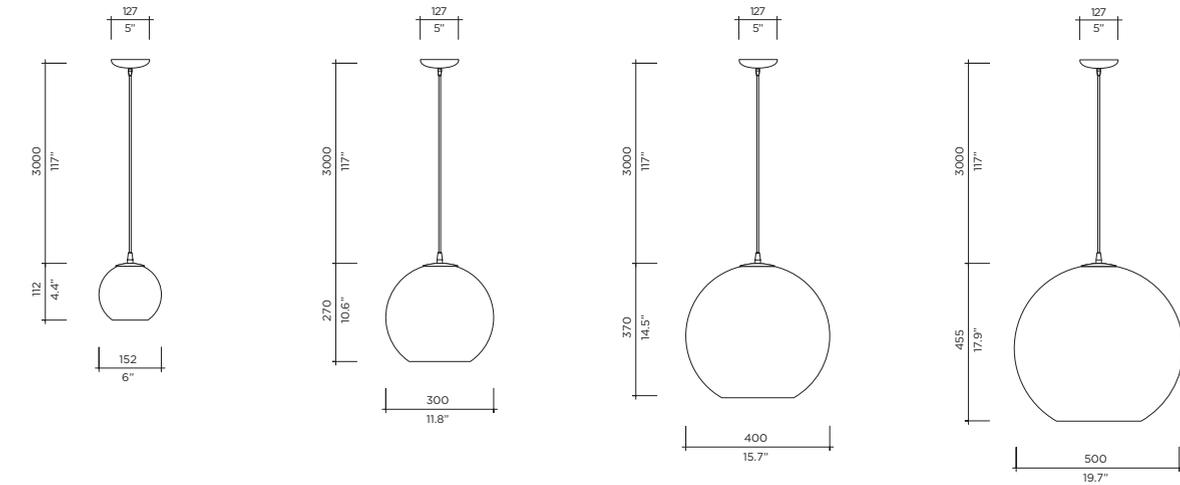

Model Size **Fort Knox Suspension**
152
Ref. # **BM.07.798__**
Bulb G-4 Bi-Pin (12V-120V/220V)
1 x 20W max (G4 Halogen)
1 x 2W LED (G4)

Model Size **Fort Knox Suspension**
300
Ref. # **SM.07.798__**
Bulb E26 / E27 (120V/220V)
1 x 60W max (Incandescent)
1 x 60W equivalent

Model Size **Fort Knox Suspension**
400
Ref. # **MM.07.798__**
Bulb E26 / E27 (120V/220V)
1 x 75W max (Incandescent)
1 x 75W equivalent

Model Size **Fort Knox Suspension**
500
Ref. # **GM.07.798__**
Bulb E26 / E27 (120V/220V)
1 x 75W max (Incandescent)
1 x 75W equivalent

	BM	SM	MM	GM
Lbs	2.5	4	7	9
Kg	1.1	1.8	3.2	4.1

ZEBRA

Swanky. Novel. Dual.

-
- Metallic and clear striped dome
- High-quality polycarbonate body
- Metalized interior
- Chrome metal canopy and components
- Custom canopies are available
- Custom metallic options are available including gold
- LED option is available upon request

—
Designer
 Filipe Lisboa



METALLIC FINISHES



Silver 12



Smoke 21

CONFIGURATIONS

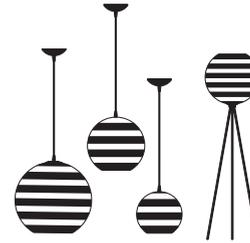

SPECS

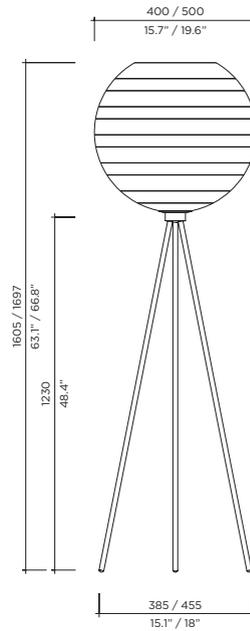
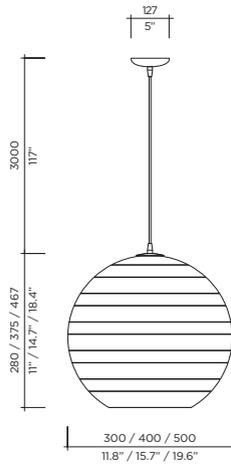

Model **Zebra Suspension**
 Size 300, 400, 500
 Ref. # SM.07.170__
 MM.07.171__
 GM.07.172__
 Bulb E26 / E27 (120V/220V)
 1 x 60w max (300, 400, 500)
 Incandescent
 1 x 60W equivalent

Model **Zebra Floor**
 Size 400, 500
 Ref. # MM.08.171__
 GM.08.172__
 Bulb E26 / E27 (120V/220V)
 1 x 60w max
 Incandescent
 1 x 60W equivalent

	SM	MM	GM
Lbs	4	7	9
Kg	1.8	3.2	4.1



RUSKII

Solid. Articulate. Present.

- Hand-painted durable porcelain body
- Gold and silver features metalized interior/exterior finish
- White and black features interior/exterior painted finish
- Custom canopies are available
- Includes silver or white canopy
- LED option is available

Designer
 Enrico Zanolla



COLOUR OPTIONS



SPECS

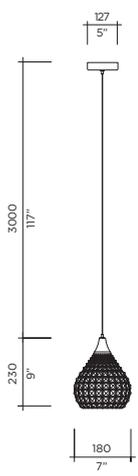

Model **Ruskii Suspension**
 Size 180
 Ref. # SM.07.941_...
 Bulb E12 / E14 (120V/220V)
 1 x 40W max
 LED 1 x 40W equivalent

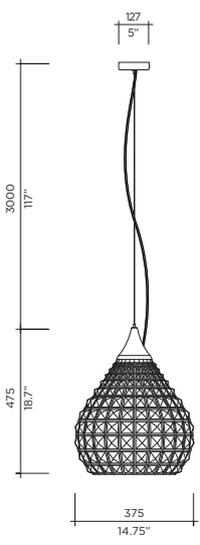

Model **Ruskii Suspension**
 Size 375
 Ref. # GM.07.941_...
 Bulb E26 / E27 (120V/220V)
 1 x 60W max (Incandescent)
 LED 1 x 60W equivalent



	SM	GM	
Lbs	3	16	
Kg	1.4	7.3	

CE	ETL
	Intertek

RUSKII TWIST

Feminine. Playful. Sophisticated.

-
- Hand-painted durable porcelain body
- Gold and silver features metalized interior/exterior finish
- White and black features interior/exterior painted finish
- Custom drops are available
- Custom canopies are available
- Includes silver or white canopy
- LED option is available

—
Designer
 Enrico Zanolla



COLOUR OPTIONS



SPECS

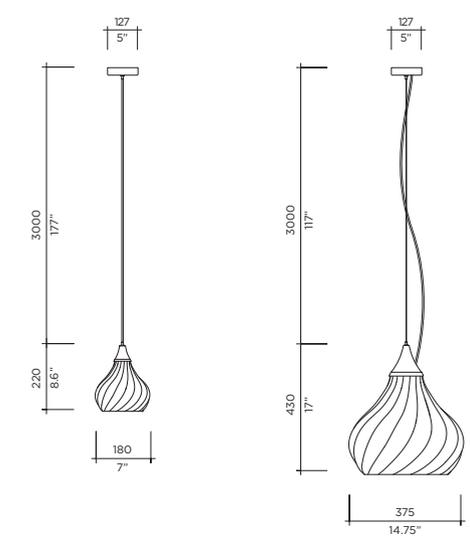

Model **Ruskii Twist**
 Size **180**
 Ref. # **SM.07.931_ _**
 Bulb **E12 / E14 (120V/220V)**
 1 x 40W max (Incandescent)
 1 x 40W equivalent

Model **Ruskii Twist**
 Size **375**
 Ref. # **GM.07.931_ _**
 Bulb **E26 / E27 (120V/220V)**
 1 x 60W max (Incandescent)
 1 x 60W equivalent



	SM	GM	CE	ETL Intertek
Lbs	3	16		
Kg	1.4	7.3		







VISO

LIGHT IS LIFE



VISO Headquarters

388 Carlaw Ave. Suite 207
Toronto, ON M4M 2T4
+1 416 461 8476

VISO Europe

Doroana Park, Nave 4
Regueira de Pontes
2415-199 Leiria, Portugal
+351 244 236 842

Inquiries

info@visoinc.com
visoinc.com

VISO
LIGHT IS LIFE

NEXT | **CUSTOM**
PROJECTS

| **CUSTOM**
| PROJECTS

VISO
LIGHT IS LIFE

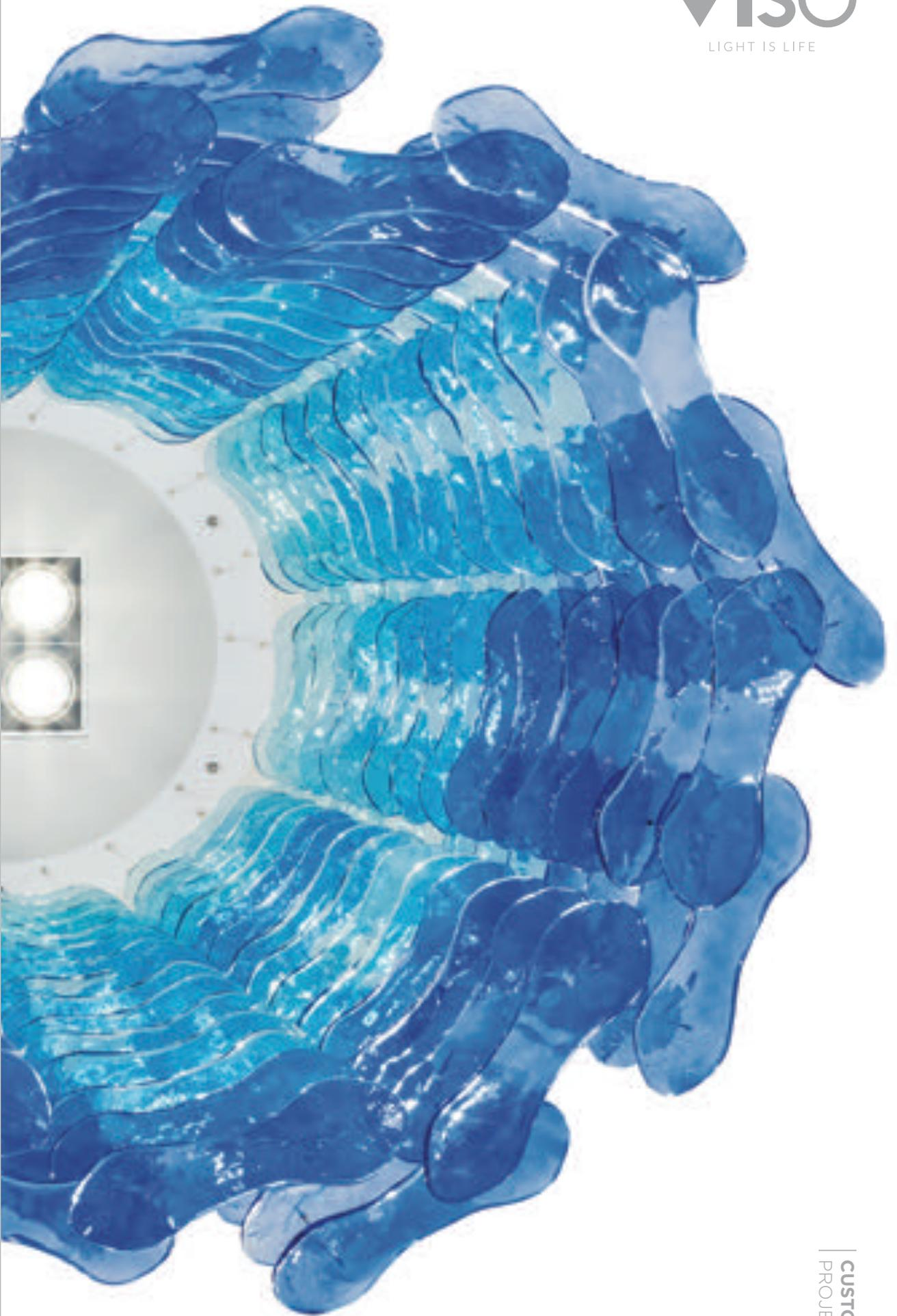

CUSTOM
PROJECTS



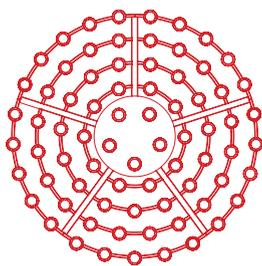

VISO CUSTOM DESIGN STUDIO

Expert Lighting Design and Manufacturing Solutions

VISO's Custom Design Studio delivers contemporary lighting solutions tailored to your project's individual needs. Beginning with your initial concept, we will apply core design principals and our proprietary unique technologies to design and manufacture an innovative lighting solution for your project.

Ideal for architects and designers, VISO's Custom Design Studio offers a full range of services. Our services include: tailor-made lighting design from initial concept to final production, 3D renderings, project lamping and structural consultation. Our knowledgeable project managers will work with you to guarantee that your project is delivered on time and on budget.

VISO's manufacturing facilities and partner divisions are equipped with the latest design and production technology. Assembly, testing and quality assurance for all projects is conducted in our Toronto-based production facility to ensure the highest quality for your final product.

Once shipped, our skilled team of technicians will ensure that your lighting fixture is installed correctly and safely through telephone consultation or on-site assistance.

Previous projects undertaken by VISO's Custom Design Studio include: VICEROY Hotels, Four Seasons Hotels & Resorts, MGM Group, Fairmont Hotels, The Ritz-Carlton, Sheraton Hotels, Grand Hyatt Hotels, and numerous casinos, bars and restaurants. Additionally, VISO is the preferred store roll-out lighting manufacturer for Tim Horton's International, McDonald's NA, Douglas European Perfumery and many more.

Projects have also been featured in numerous film and television spots including Casino Royale, X-Men and The Bounty Hunter.

Please inquire within for project details and custom capabilities.



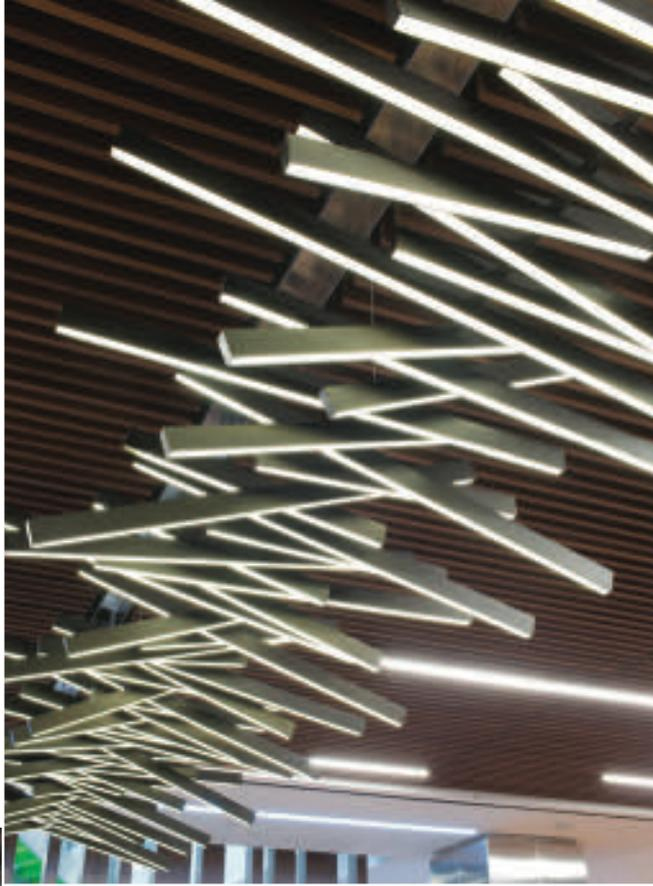

—
Project
Deloitte Office
Toronto, Ontario

Interior Design
Mulvey & Banani

Photographer
David Wile

—

Project Overview

In partnership with Mulvey & Banani, VISO created a linear light pendant featuring a series of branch-like components. Each component rotates horizontally and vertically on the pendant's center axis, giving the fixture an organic, living feel.

—

Project Specs

The fixture measures 189"/4800mm in length and 49"/1244mm in width. A total of 63 branch-like components were manufactured using powder-coated aluminum in two sizes: 24"/610mm and 40"/1016 with the body measuring 1"/25mm wide by 2"/51mm tall. Each component houses a 2000K-15W dimmable LED strip with a white translucent acrylic diffuser.

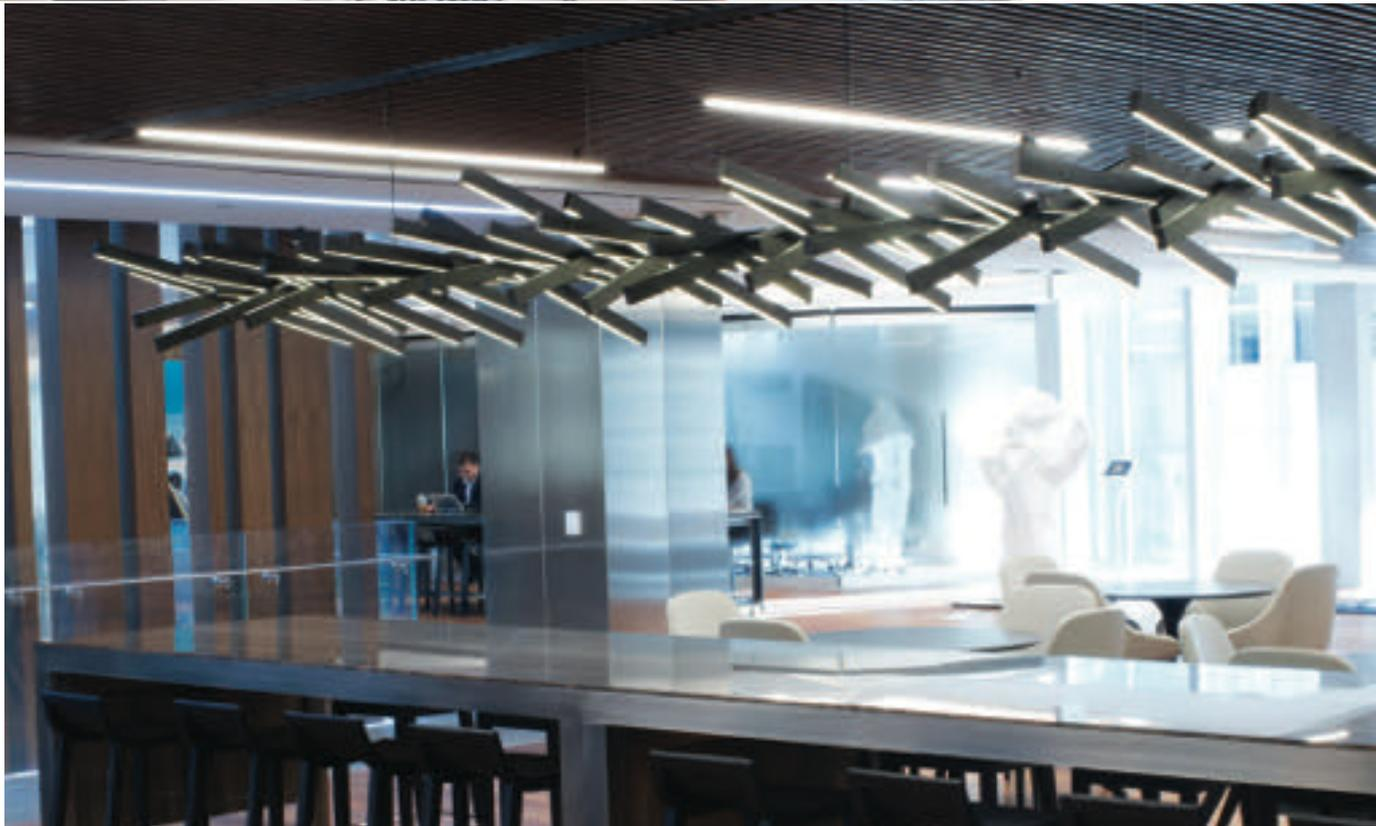



INTERACE



Project
The Terrace Shopping Centre
Halifax, Nova Scotia

Architect
MMC Architects

Photographer
Julian Parkinson

Project Overview

Known as "The Fish", VISO created four identical sculptural glass chandeliers for the reopening of The Terrace. The chandeliers feature 270 glass fish arranged to create a colour gradient from dark blue to light blue to resemble the ocean.

Project Specs

Four identical fixtures include a total of 1108 glass fish pendants. Each 300lb/136Kg fixture hangs from a 4"/102mm metal arch for stability. Installed in vertical stacks, 36 aircraft cables hold each fish precisely in place. Accurate spacing and fish drop distribution is achieved by alternating angles of 20°, 21°, 17° and 23°.







—
Project
Beaumont Kitchen
Toronto, Ontario

Interior Design
Moncur Design Associates Limited

Photographer
David Wile

—
Project Overview

Commissioned by Oliver & Bonacini, VISO design-engineered and manufactured custom decorative lighting including a centerpiece chandelier affixed to a heritage column in the center of the room.

—
Project Specs

A circular hairline bronze cuff structure was designed to affix to the column. The cuff measures 32.5"/826mm in circumference, 25"/635mm in height and 4"/102mm in depth. 53 brushed metal arms measuring 113"/287mm and 28"/711mm in length hold LED Edison bulbs.







Project
 Cascades Casino
 Kamloops, British Columbia

Interior Design
 mackaywong

Photographer
 David Whittaker

Project Overview

As the preferred decorative lighting provider for the project, VISO created numerous chandeliers and light pendants that can be found throughout the casino. High quality materials including brass, crystal and glass were used to bring the chandeliers to life.

Project Specs

Six sets of colour-changing RGB crystal oval rings can be found on the gaming floor measuring up to 240"/6096mm on its longest axis. The restaurant chandelier features 24 waves of orange glass with a total of 1,108 drops. Eighty-eight sleek chrome twigs resembling antlers adorn the bar while an ornate sculpture resembling a fossilized pre-historic animal is hung in the private dining area.







—
Project
STK Steakhouse
Toronto, Ontario

Interior Design
DesignAgency

Photographer
David Wile

—
Project Overview

In collaboration with DesignAgency, VISO was the preferred decorative lighting brand for STK's first Canadian restaurant. Unique materials including marble, hairline bronze and magnified glass were used to create modern wall sconces and a chandelier in the restaurant's private dining room.

—
Project Specs

A hairline bronze metal ring chandelier measuring 36"/914mm in diameter holds 8 Wandering Star pendants constructed of marble, magnified glass and bronze metal finishes. Weighing upwards of 40 lbs/18 kg, the structure is hung by 4 galvanized steel aircraft cables. Three matching Wandering Star wall sconces were designed to compliment the chandelier.

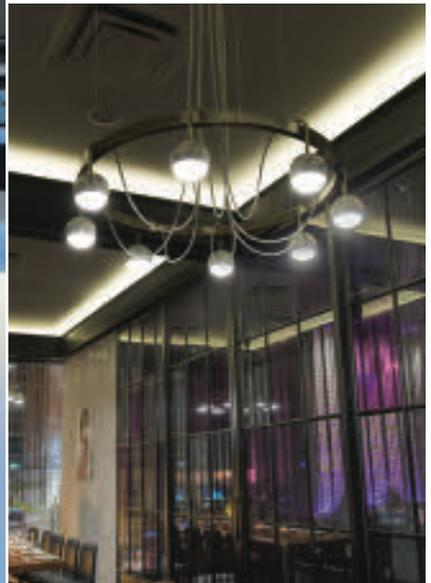





—
Project
Pearson International Airport
Toronto, Ontario

Interior Design
Stantec

Photographer
VISO Inc.

—
Project Overview

Working closely with Stantec, VISO designed and manufactured a custom chandelier featuring 64 tapered chrome light pendants. Each pendant includes an oversized frosted acrylic diffuser, which casts an inviting glow both day and night.

—
Project Specs

Oversized custom canopy measuring 132"/3353cm in diameter designed to suspend 64 tapered chrome light pendants at varying heights up to 360"/9144mm from the ceiling. A similar pendant, named Alo, is now available as part of our Brand Collection.







Project
Buca Restaurant
Toronto, Ontario

Interior Design
Guido Costantino

Photographer
April Maciborka & David Wile

Project Overview

For Buca's Yorkville restaurant, VISO developed a series of linear light installations manufactured using polished steel and frosted glass bulbs. Decorative wall sconces were also created to illuminate the restaurant's graphic tiled walls.

Project Specs

A chandelier measuring 143.5"/3645mm long by 71.5"/1816mm wide was designed for the entrance of the restaurant. It features 220 linear brass tubes that hang in a large rectangular formation. Each brass tube varies in length to create three-dimensional depth. The chandelier weighs upwards of 2,640 lbs/1197 kg.

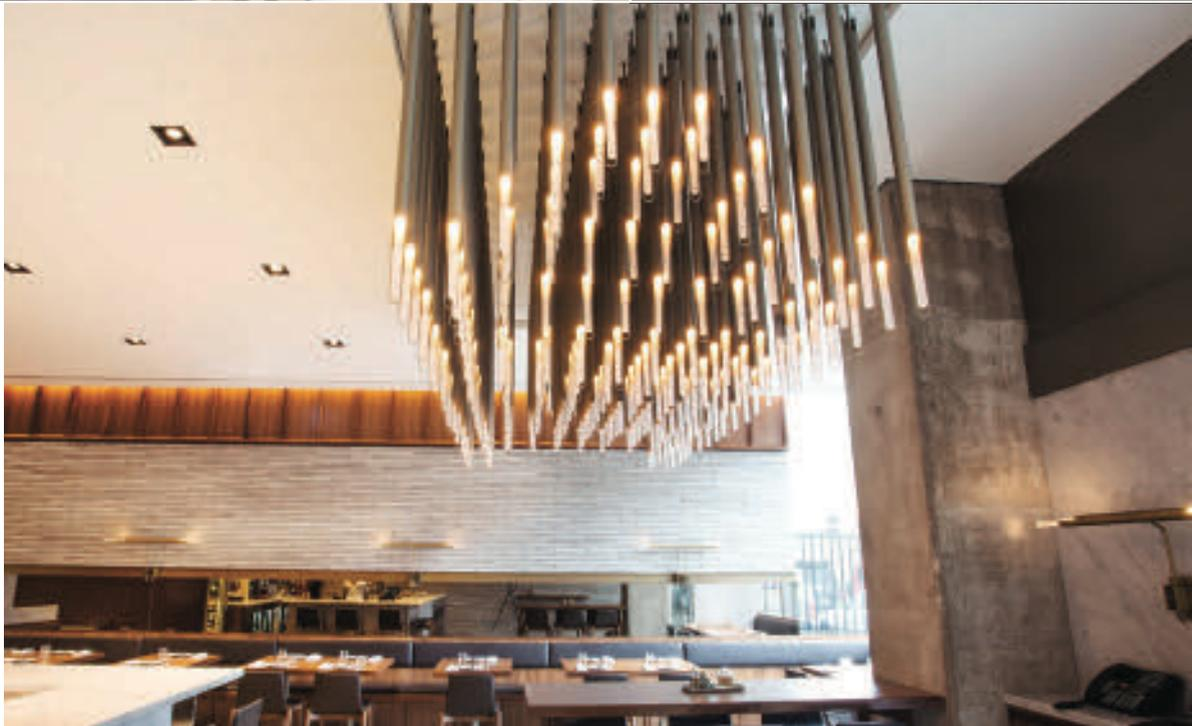



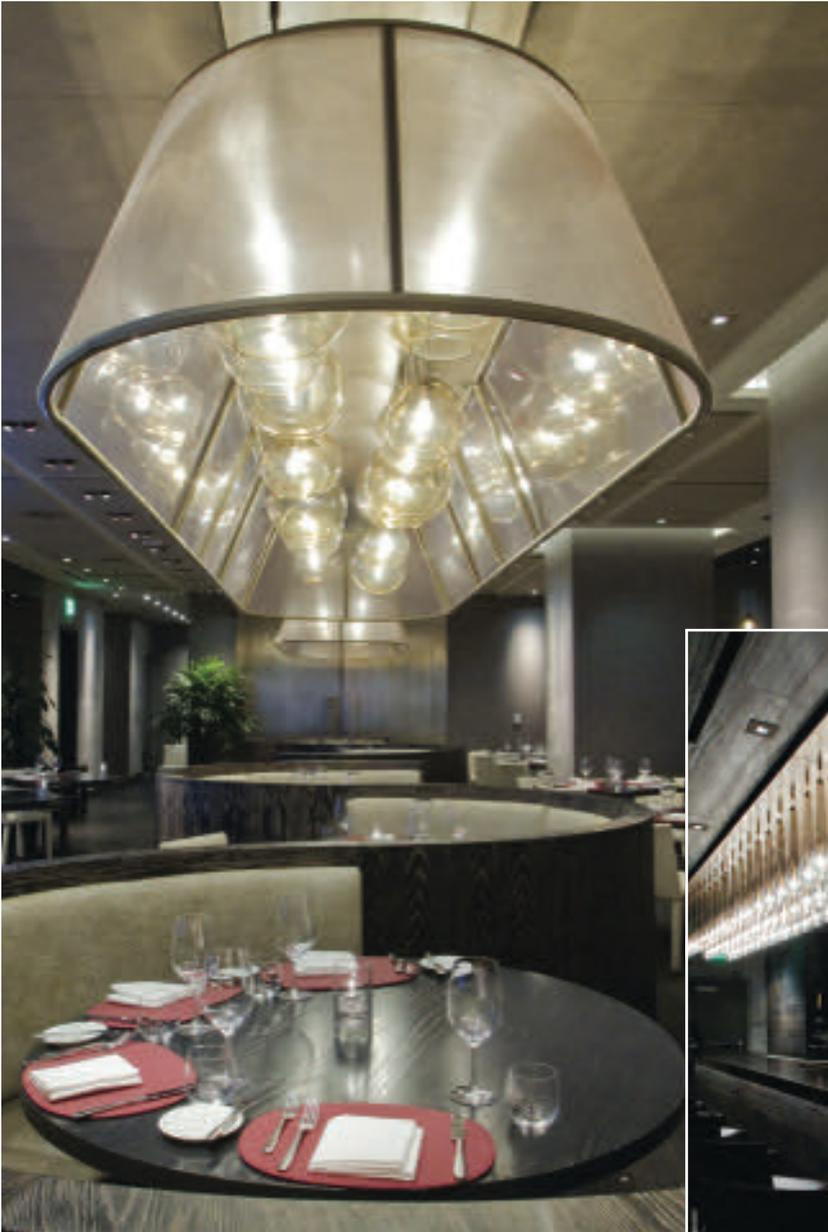

—
Project
Scarpetta, Cosmopolitan Casino
Las Vegas, Nevada

Interior Design
Studio Gaia

Photographer
Scarpetta

—
Project Overview

Commissioned for Scott Conant's Las Vegas restaurant, VISO designed numerous decorative light pendants and chandeliers for Scarpetta at the Cosmopolitan Hotel. Featuring oversized iridescent shades and custom teardrop orbs, the decorative fixtures can be found throughout the space.

—
Project Specs

Oversized lampshades were manufactured using custom metal frames finished in gold metallic paint. Large amber glass globes were used to create warm, inviting light.



Project
Thompson Hotel
Toronto, Ontario

Interior Design
Studio Gaia

Photographer
DEVICE222

Project Overview

A custom chandelier adorns the bar at the Thompson Hotel in Toronto. Made of stainless steel and glass teardrops, the fixture anchors the room. VISO's Gemma crystal fixture is also showcased in a massive installation illuminating a graphic mural of Toronto.

Project Specs

Two-tier rectangular custom chandelier finished in brushed metal chrome featuring over 125 hand blown glass teardrop pendants.

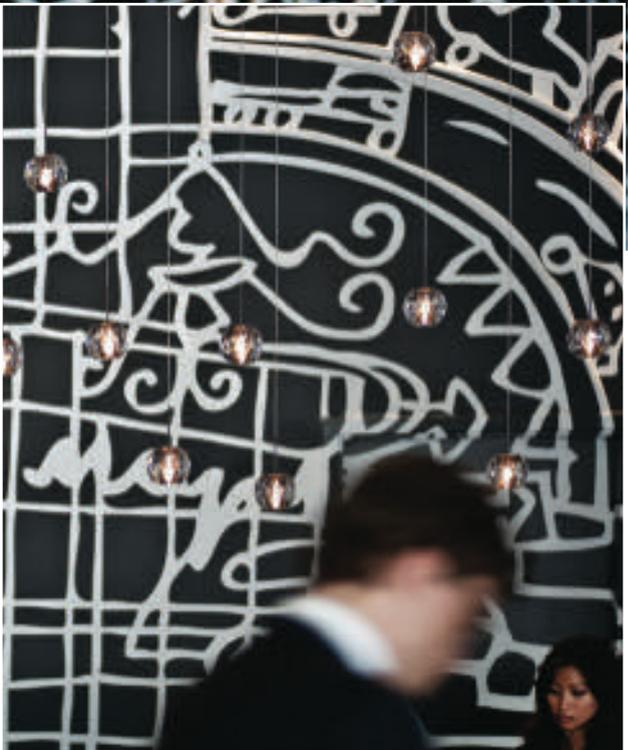
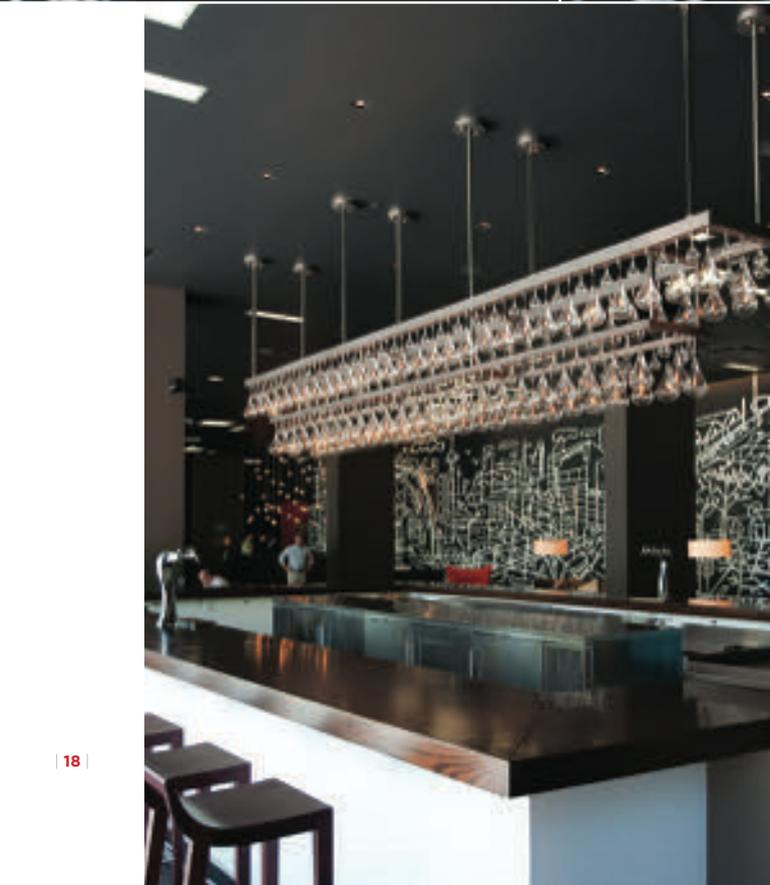



Project
The Carbon Bar
Toronto, Ontario

Interior Design
Giannone Petricone Associates

Photographer
Paula Wilson

Project Overview

VISO produced intricate drops for our Globo fixture and custom metalized polycarbonate globes. A large centerpiece chandelier was designed and hung over the restaurant's bar. Custom fabric screens used for decorative effect were also printed and produced by VISO.

Project Specs

Custom designed Globo light pendants adorn intricate 15"/381mm expandable accordion drops manufactured out of matte black powder coated metal. Environmentally friendly LED bulbs power each fixture. Numerous abstractions of our Rhea LED fixtures were also installed around graphic fabric panels over the bar.





Project

America Restaurant
Toronto, Ontario

Photographer

April Maciborka & David Wile

Project Overview

VISO design-engineered circular light box shades that were affixed to adjustable arms allowing the restaurant to change the direction of the fixtures for a dramatic effect.

Project Specs

Large custom lamp shades measuring 60"/1524mm wide and 15"/381mm tall were manufactured using black fabric and include a white chintz diffuser on the top and bottom. Custom drops measuring 126"/3200mm were fabricated out of matte black powder coated metal and include a swivel lock that allows the shade to be rotated up and down by 160°.



Project
South Beach Condominium
Sales Office
Toronto, Ontario

Photographer
David Whittaker

Project Overview

VISO design-engineered and manufactured a series of oversized lampshade fixtures using high-end fabrics and accent materials including teardrop crystals. Custom floor and desk lamps were also developed using lacquered wood finishes.

Project Specs

Five oversized shades were created as an abstraction of our Marini and Velvet fixtures with custom dimensions. Each shade was covered in Fornasetti fabric on the inside and black velvet on the outside. Swarovski crystals cascade at various heights inside each shade.





Project
Montecito Restaurant
Toronto, Ontario

Interior Design
mackaywong

Photographer
April Maciborka & David Wile

Project Overview

Inspired by the California coastline, VISO design-engineered numerous decorative lighting fixtures for Ivan Reitman and Jonathan Waxman's Toronto restaurant with an aim to create a soft and relaxing atmosphere.

Project Specs

Wall-mounted fixtures consisting of linen lampshades measuring 32"/813mm by 17"/432mm and counterweight systems to adjust the height of the shade using a pulley system were designed for the main dining room. The two chandeliers in the bar area feature a total of 30 silver semi-metalized polycarbonate globes affixed to a matte black powder-coated metal structure.

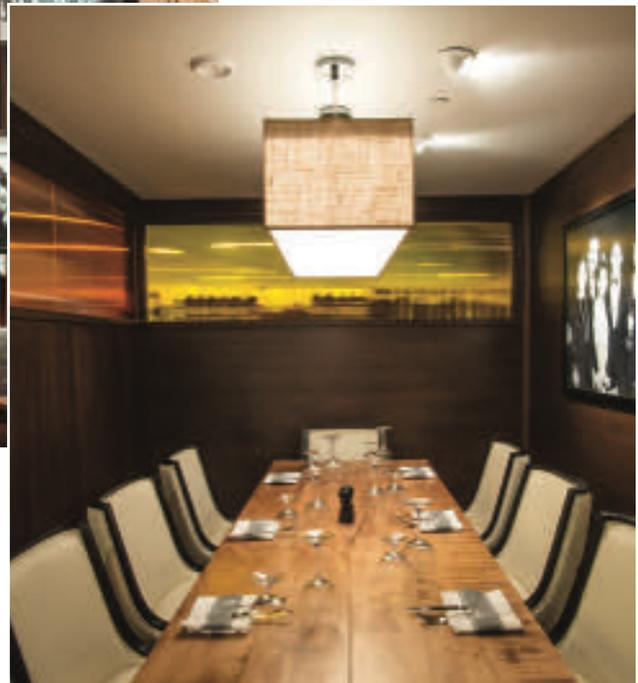





Project
Leña Restaurant
Toronto, Ontario

Interior Design
DesignAgency

Photographer
David Wile

Project Overview

Located in Saks Fifth Avenue's Toronto flagship store, VISO produced custom restaurant lighting in an Art Deco style. An oversized hairline bronze light installation was affixed to a heritage column at the centre of the restaurant's bar.

Project Specs

A custom cladding structure was installed around the heritage column in the bar area which includes 21 hairline bronze brass arms that support pear-shaped frosted glass orbs. A second chandelier in the main dining room features ten circular LED pendants measuring 11"/279mm in diameter and finished in hairline bronze. The pendants are supported by matte black coated tubes and canopies.







—
Project
NAO Steakhouse
Toronto, Ontario

—
Photographer
April Maciborka and David Wile

—
Project Overview

Commissioned by Hanif Harji and Charles Khabouth, VISO produced a chandelier to act as the cornerstone design element of the restaurant. Carefully assembled using plexiglas tubes of various sizes, the chandelier features a steel tube outfitted with multiple LEDs to disperse light evenly.

—
Project Specs

Measuring 90"/2286mm in diameter and 106"/2692mm in height, the chandelier features more than 50 clear acrylic tubes in various heights and includes four T5 58W 3000K LED strips in the central metal column. The fixture is supported by 3 aircraft cables and is finished with a mirrored acrylic canopy.

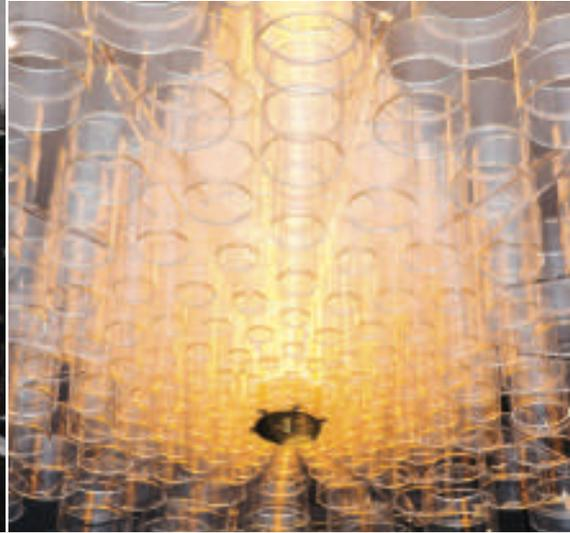

RENDERS

VISO's Custom Design Studio provides each client with fully realized 3D renderings of all proposed lighting solutions including fixture dimensions, materials and light source requirements for every project. View a selection of our work.



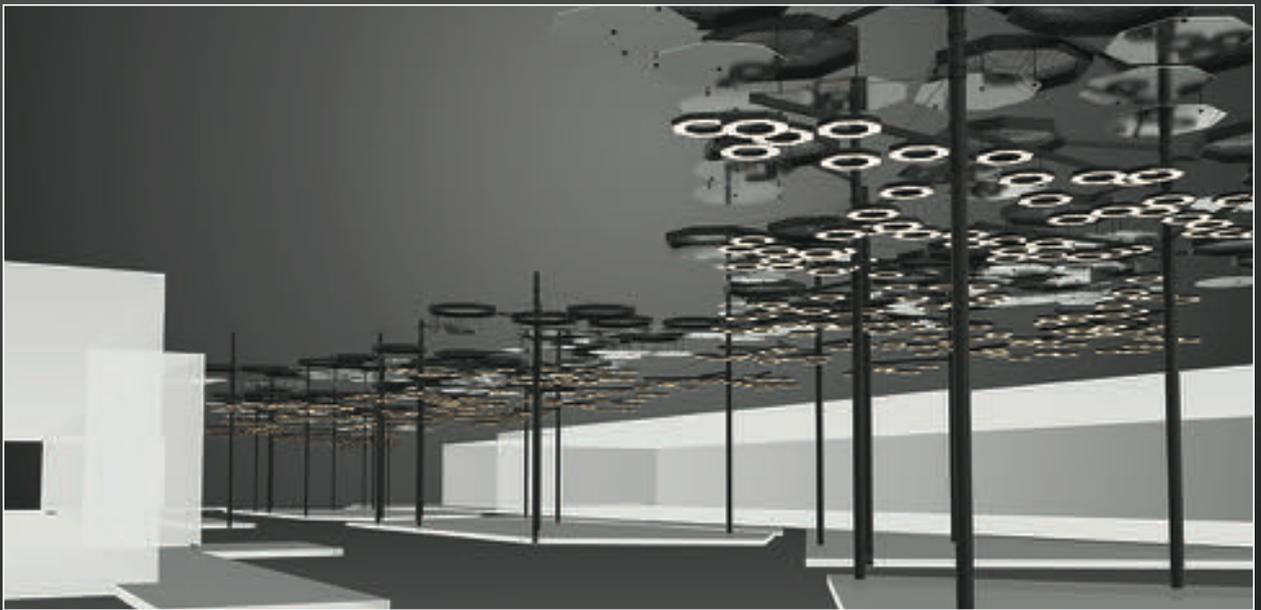

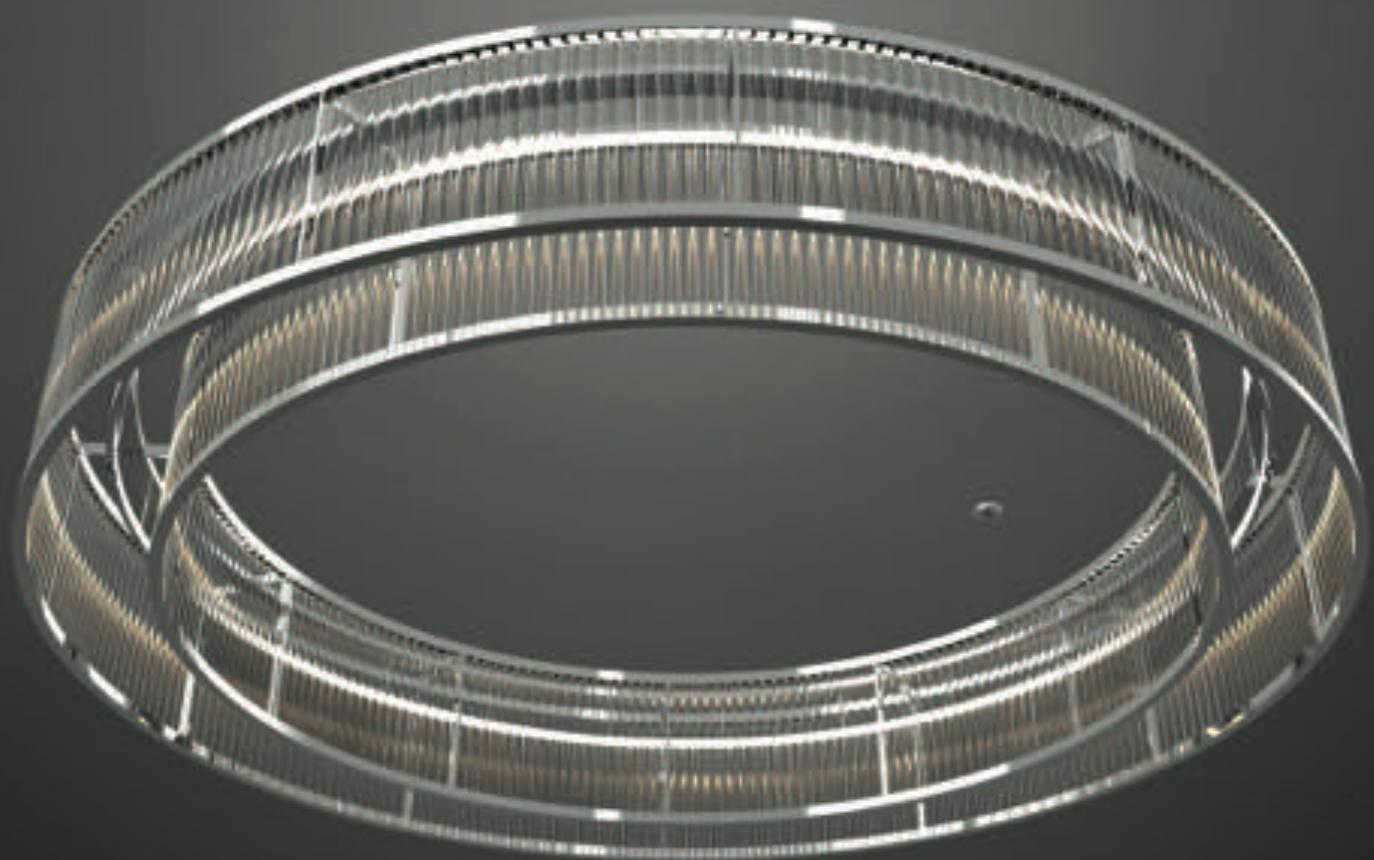
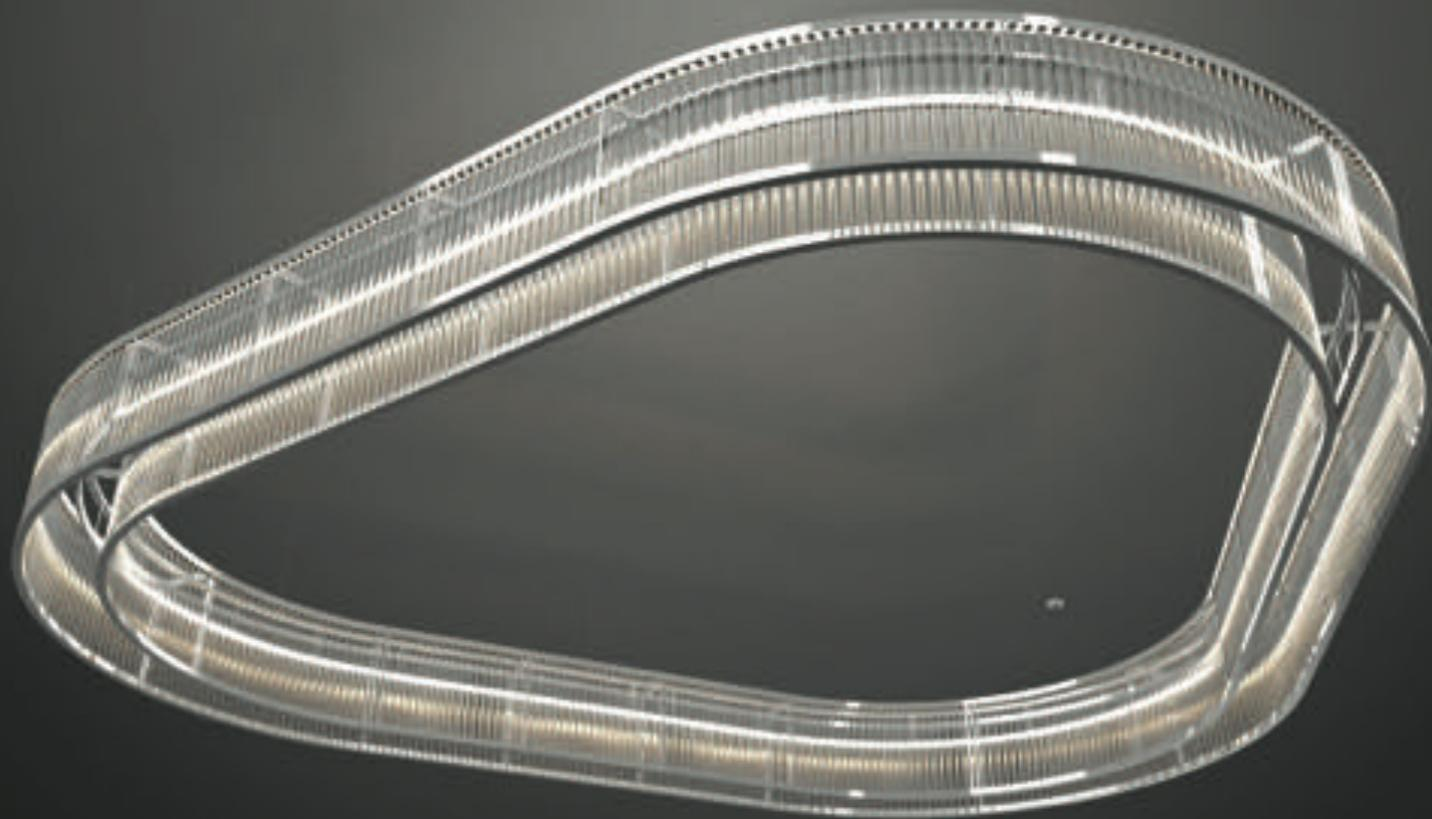



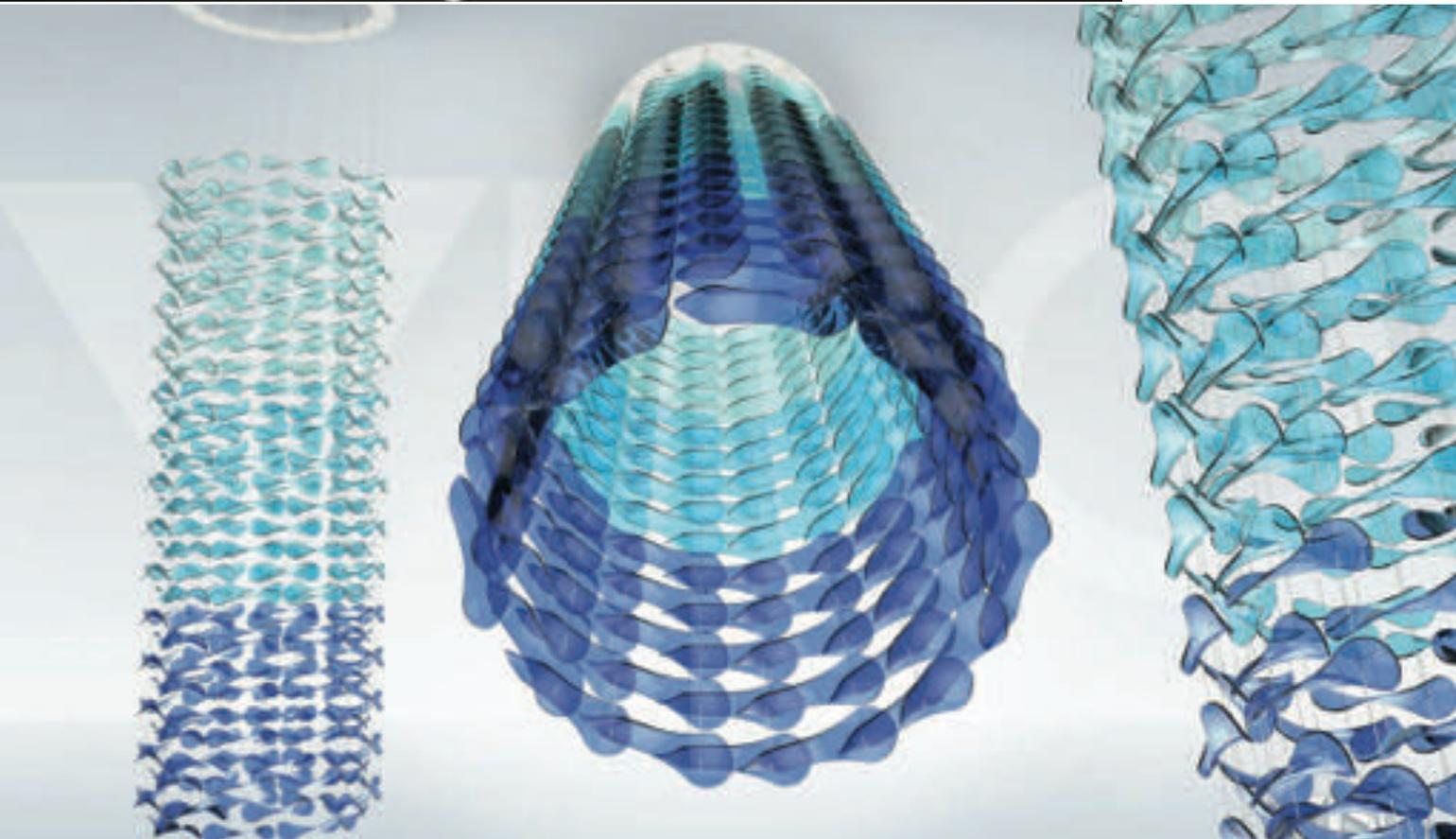
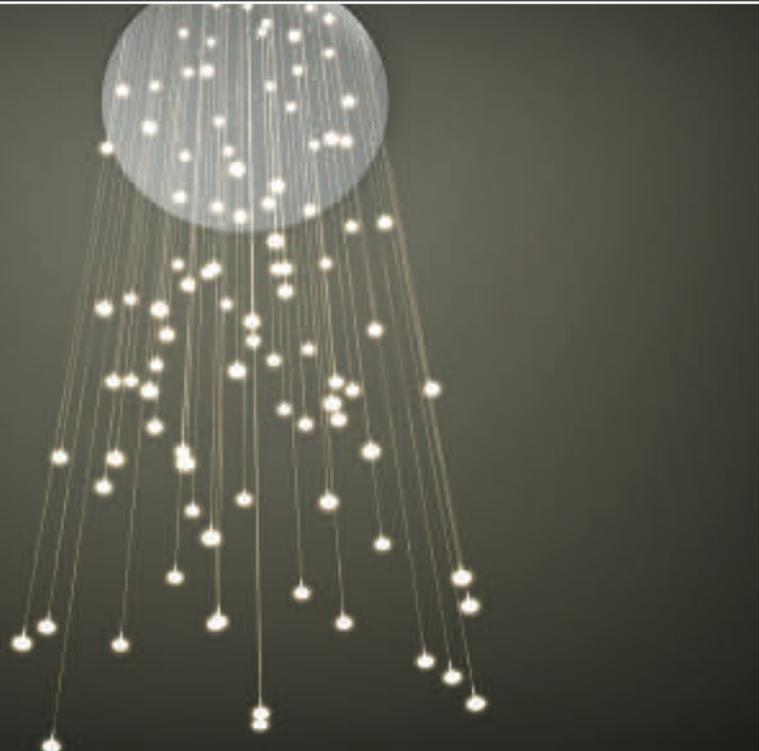
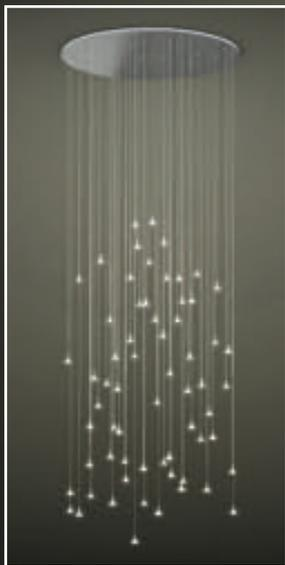





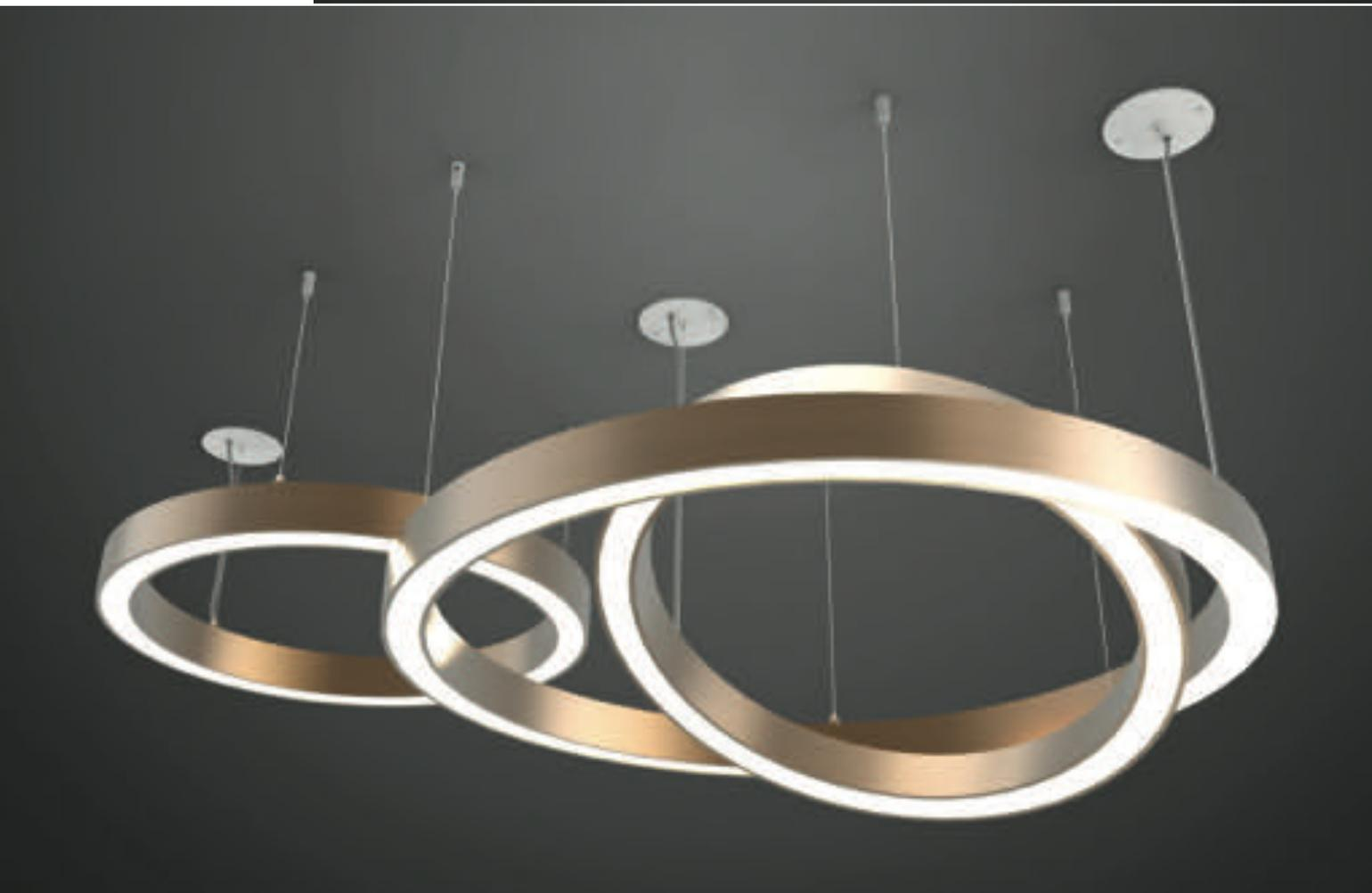
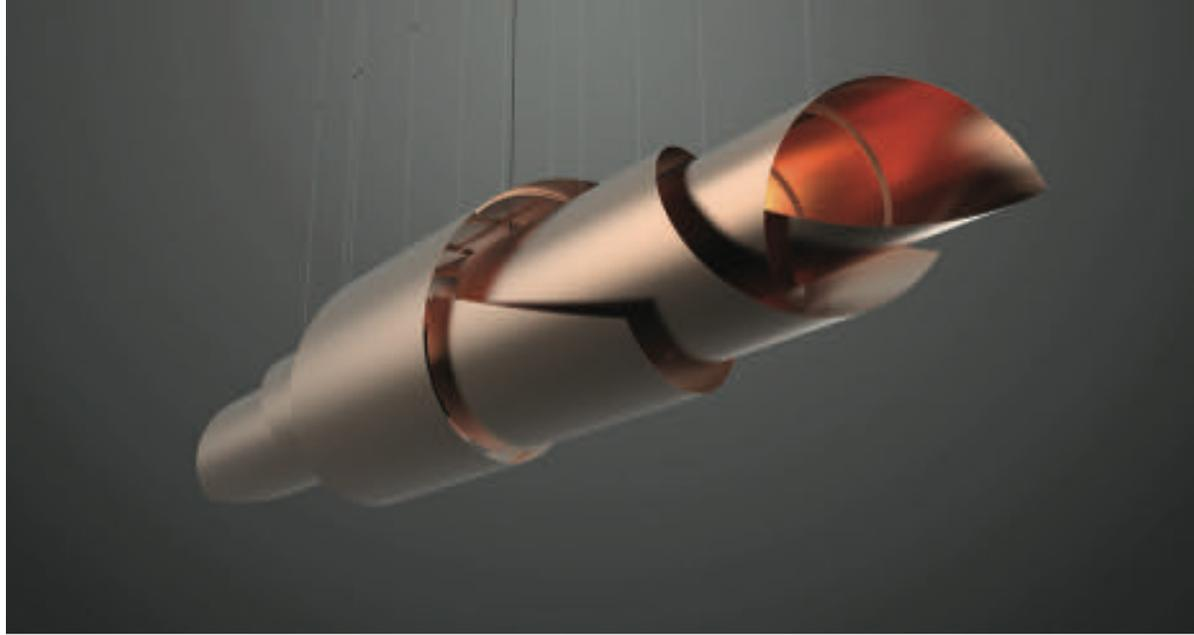

ORDER REALIZATION PROCESS

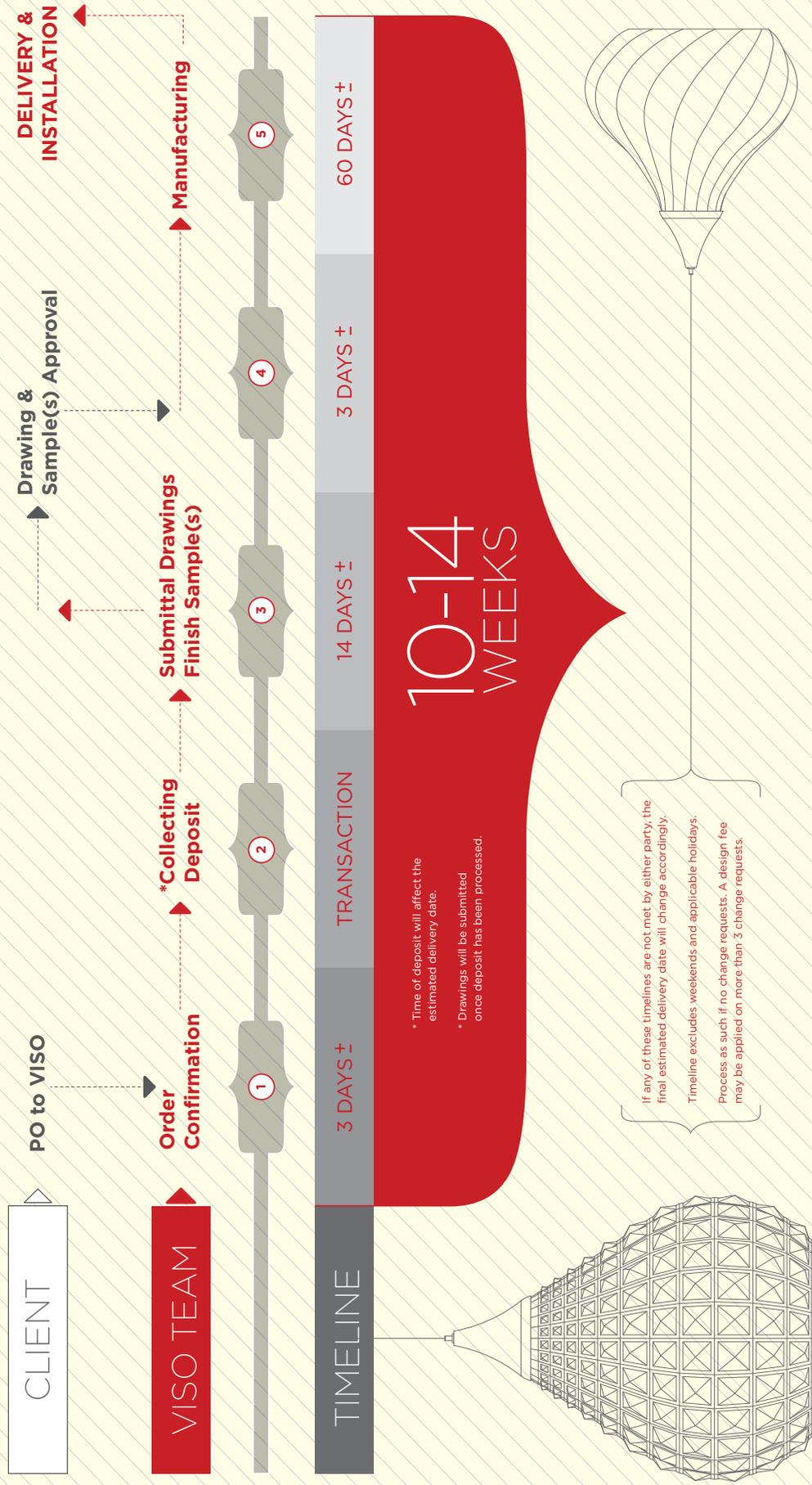

VISO
LIGHT IS LIFE

VISO

LIGHT IS LIFE

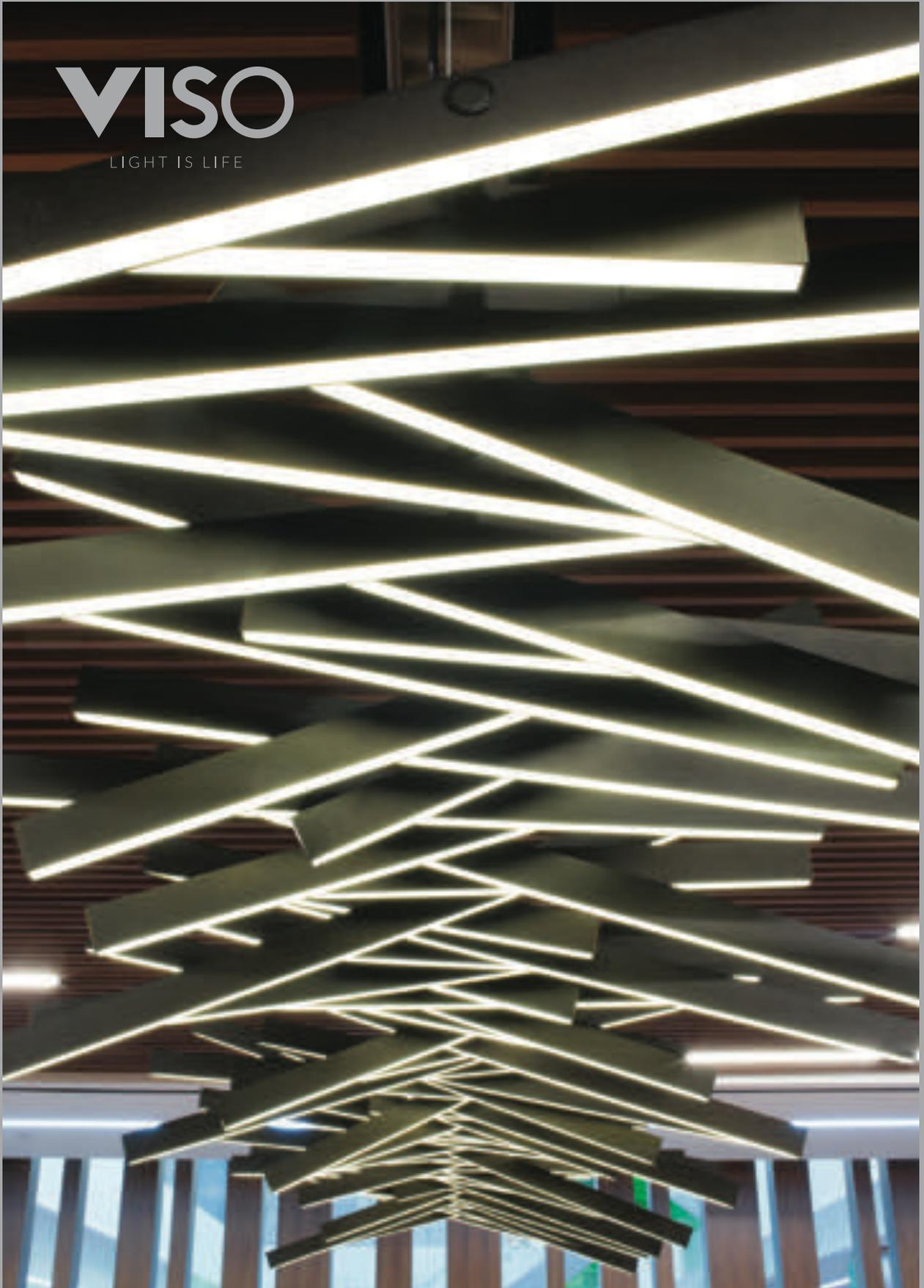

VISO Headquarters

388 Carlaw Ave. Suite 207
Toronto, ON M4M 2T4
+1 416 461 8476

VISO Europe

Doroana Park, Nave 4
Regueira de Pontes
2415-199 Leiria, Portugal
+351 244 236 842

Inquiries

info@visoinc.com
visoinc.com



WOJNAROWSKI

tel . 32 735 0 537
biuro@wojnarowskilighting.pl

Porcelanowa 23, bud. B
40-246 Katowice

NIP: 9542793763
REGON: 380582520

WWW.WOJNAROWSKILIGHTING.PL